

# TAD1371-1375VE

12.78 litre, in-line 6 cylinder - 285, 315, 345, 375 & 405 kW

EU Stage IV / US EPA Tier 4 Final

TAD1371-1375VE is a powerful, reliable and economical off-road Diesel Engine range built on the Volvo Group in-line six concept.

## Low cost of ownership

World class fuel efficiency combined with high uptime as well as low cost of ownership.

## Compact & simple installation

As optional equipment all material needed in order to install the engine can be ordered from Volvo Penta. Installation guidelines as well as drawings and CAD models are easy to access. The result is an engine that is easy to install.

## Durability & low noise

Long experience with base engine development reduces risk of downtime. Well-balanced to produce smooth operation with low noise.

## Power & torque

Maximum power and torque available at low rpm. As a result noise as well as fuel consumption is very low. Useful engine speed for the TAD1371-1375VE is due to power and torque layout very flexible.

## Low exhaust emission

Efficient injection as well as robust engine design in combination with optimised SCR technology and a light EGR contributes to excellent combustion and low fuel consumption.

## Easy service & maintenance

Easily accessible service and maintenance points contribute to the ease of service of the engine. As optional equipment possible to remote mount filters and service points.

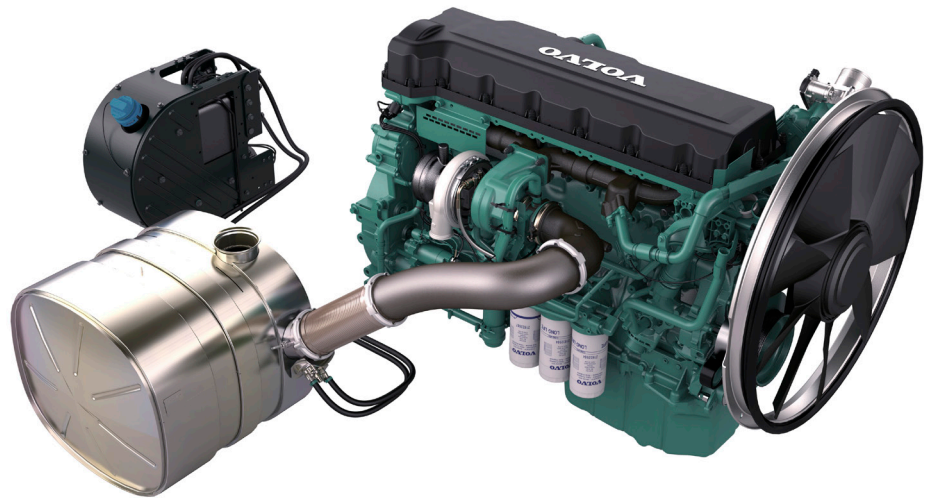

- Proven and straight-forward design - built on Volvo Group technology
- Low cost of ownership and operation
- High power and torque already at low engine speed
- SCR and light EGR only - no DPF, DOC or regeneration
- Compact, simple installation and easy to service
- Similar engine footprint for all emission standards
- Wide range of optional equipment

## Technical description

### Engine and block

- Cast iron cylinder block
- Wet, replaceable cylinder liners
- Replaceable valve guides and valve seats
- Overhead camshaft and four valves per cylinder

### Lubrication system

- Full flow disposable spin-on oil filter, for extra high filtration
- Gear type lubricating oil pump, gear driven by the transmission
- Oil level sensor at startup

### Fuel system

- Electronic high pressure unit injectors
- Fuel prefilter with water separator and water-in-fuel indicator / alarm
- Gear driven low-pressure fuel pump
- Fine fuel filter with manual feed pump and fuel pressure switch

### Cooling system

- Available as power pack or base engine.
- Belt driven coolant pump with high degree of efficiency

### Turbo charger

- Electronically controlled Waste-gate

### Electrical system

- Engine Management System (EMS) 2.3, an electronically controlled processing system which optimizes engine performance. It also includes advanced features for diagnostics and fault tracing.
- The instruments and controls connect to the engine via the CAN SAE J1939 interface. Options available for engine control equipment.

### Exhaust aftertreatment system

- SCR and light EGR only
- Airless urea injection
- Wide range of options available, including different sized AdBlue® / DEF tanks (also possible for OEM to design own tank).
- AdBlue/DEF Quality Level Temperature Sensor for US Market

**VOLVO  
PENTA**

# TAD1371-1375VE

## Technical data

Engine designation .....	TAD1371-1375VE
Configuration and no. of cylinders .....	in-line 6
Displacement, l (in <sup>3</sup> ).....	12.78 (780)
Method of operation .....	4-stroke
Direction of rotation (viewed towards flywheel).....	anti-clockwise
Bore, mm (in.).....	131 (5.16)
Stroke, mm (in.).....	158 (6.22)
Compression ratio.....	17.8:1
Dry weight, engine only, kg (lb).....	1267(2793)

Engine	kW	Hp	rpm	Max Nm
TAD1371VE	285	388	1900	1965
TAD1372VE	315	428	1900	2175
TAD1373VE	345	469	1900	2380
TAD1374VE	375	1900	2595	
TAD1375VE	405	551	1900	2650

Power, kW

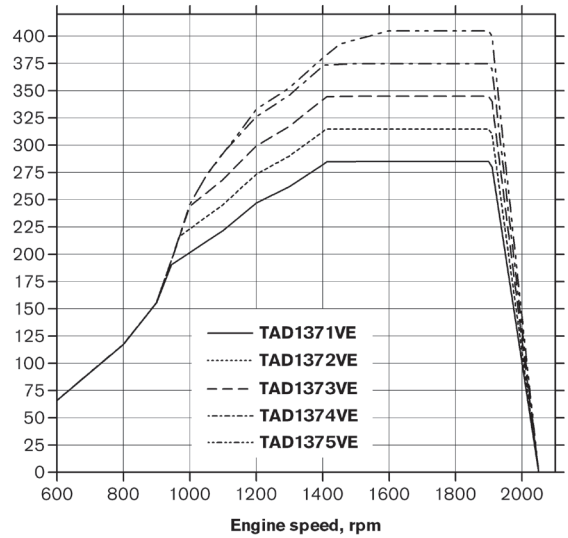

## Main components, Principal layout

The illustration shows the main components of the aftertreatment system and its piping connections.

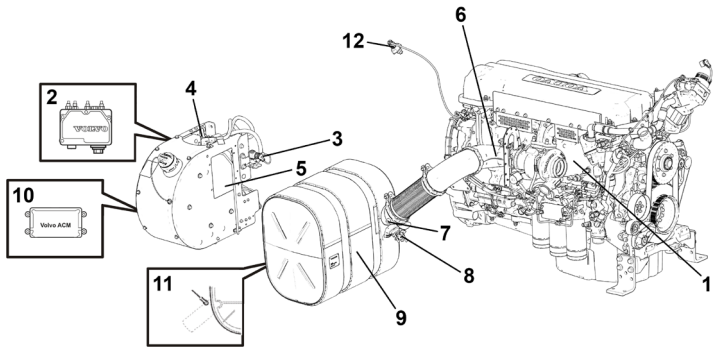

- 1. Engine
- 2. Pump Unit (PU)
- 3. Solenoid Valve, heating/cooling
- 4. AdBlue/DEF Level Temperature Sensor for EU Market  
AdBlue/DEF Quality Level  
Temperature Sensor for US Market
- 5. AdBlue/DEF Solution Tank
- 6. NOx Sensor
- 7. Temperature Sensor Exhaust
- 8. Dosage Valve (DV)
- 9. Muffler with Catalytic Converter
- 10. Aftertreatment Control Module (ACM)
- 11. NOx Sensor
- 12. Temperature Sensor Air

Torque, Nm

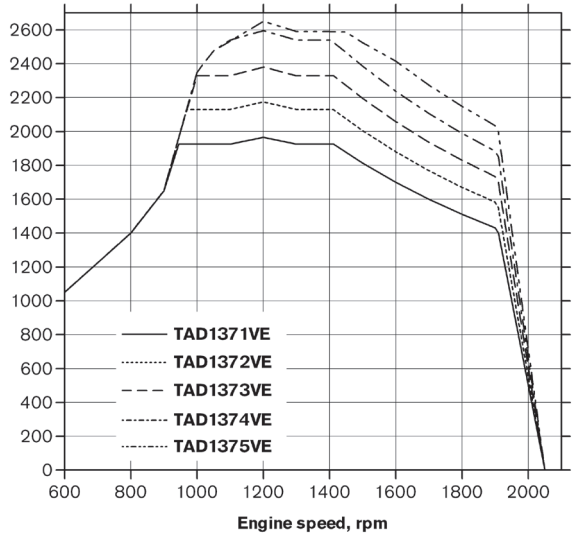

## Dimensions

Not for installation. Dimensions in mm.

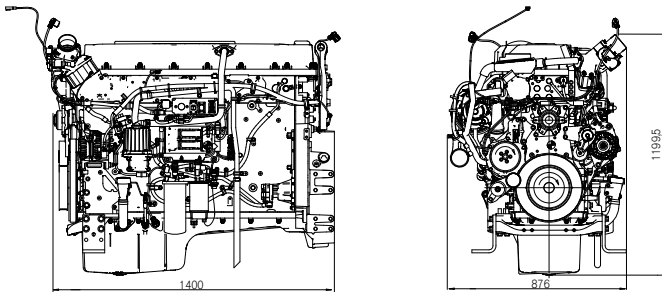

Fuel consumption, g/kWh

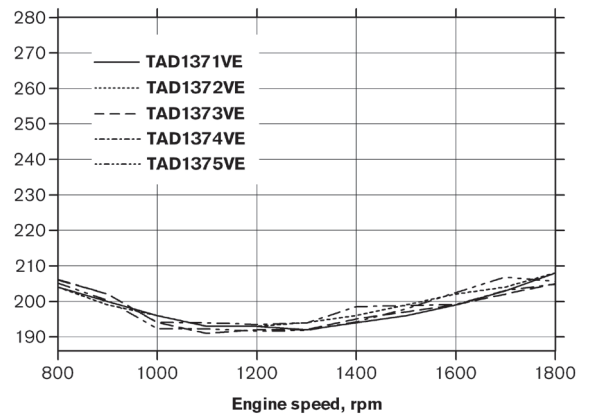

### Power standards

The engine performance corresponds to ISO 3046, BS 5514 and DIN 6271. The technical data applies to an engine without cooling fan and operating on a fuel with calorific value of 42.7 MJ/kg (18360 BTU/lb) and a density of 0.84 kg/litre (7.01 lb/US gal, 8.42 lb/Imp gal), also where this involves a deviation from the standards.

### Additional information

For additional information, please contact your Volvo Penta representative or visit [www.volvopenta.com](http://www.volvopenta.com).

# VOLVO PENTA

AB Volvo Penta

SE-405 08 Göteborg, Sweden  
[www.volvopenta.com](http://www.volvopenta.com)

Not all models, standard equipment and accessories are available in all countries. All specifications are subject to change without notice. The engine illustrated may not be entirely identical to production standard engines.