

VOLVO PENTA

D13 Industrial Information – Theoretical Pretraining

TAD 1350

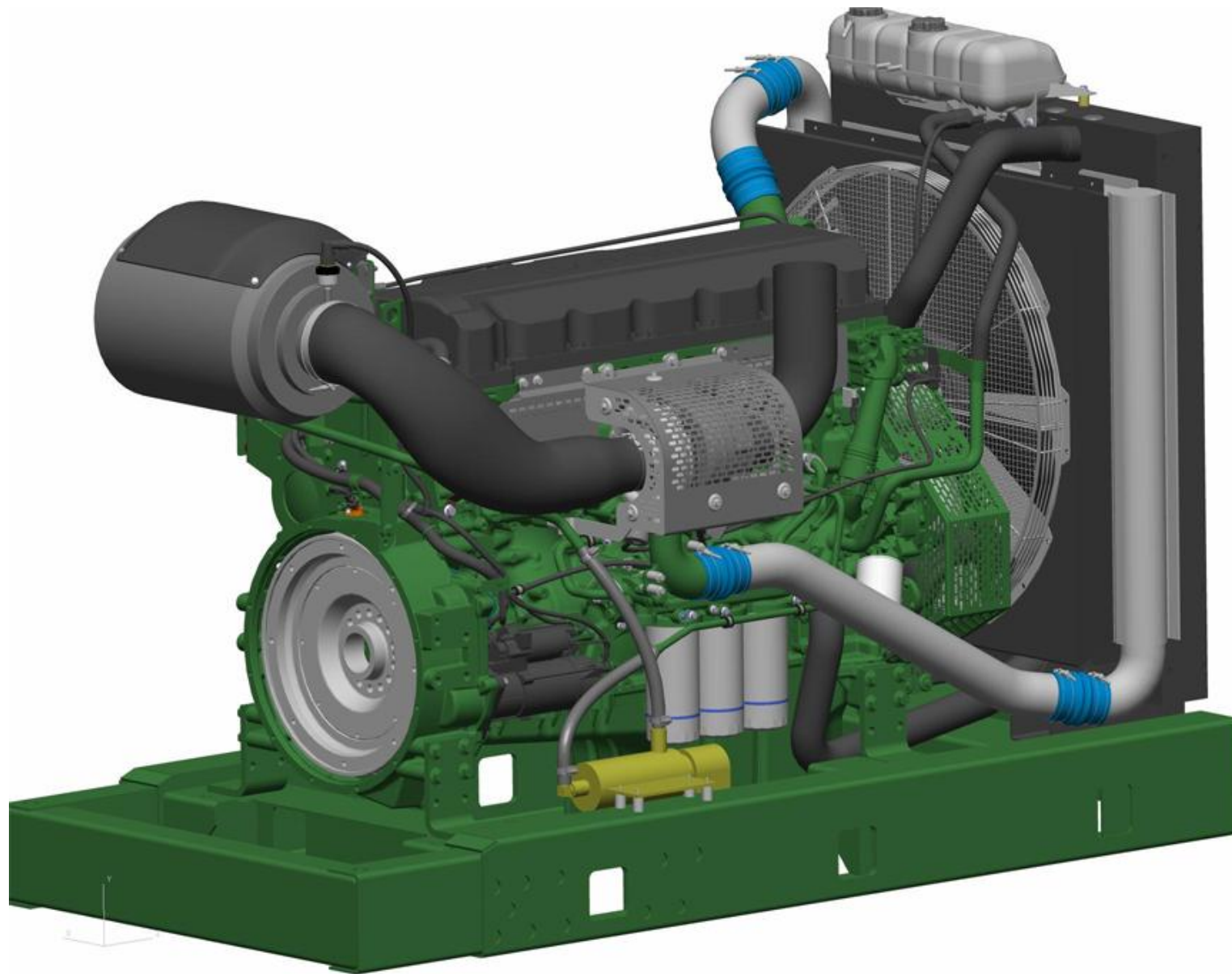

VP-SSK-1234-A-EN

Background / Commonality

D9/16 difference to D12

- Rear transmission
- CIU mandatory for stand alone interface
- EMS2 replace EMS1
- Injector trim (VODIA)



TAD135xGE

D13 difference to D9/16

- EMS2.2 replace EMS2.?
- Emission level - tier 3
iEGR , Miller-timing



TAD94xGE

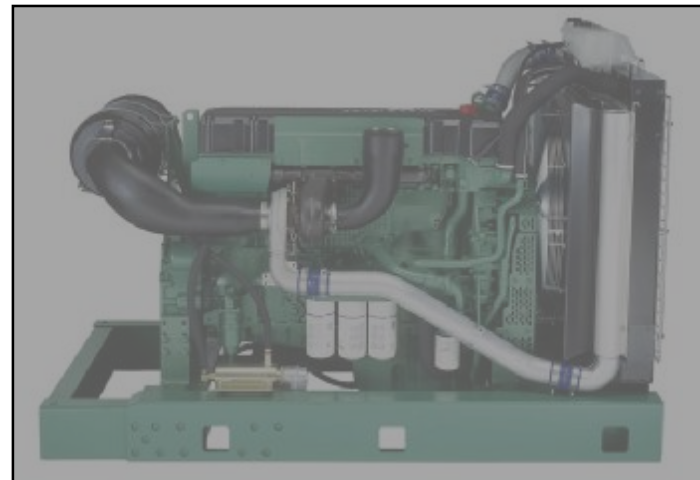

TAD124xGE



TAD164xGE

Power settings – Genset Tier 3

Spec	Rpm	Level	Net. Power kw	Power Setting kW	Gen. Eff.	kWe	kVA
TAD1350GE	1800	Prime	244	259	0,93	227	284
::	1800	St-By	269	284	0,93	250	313
TAD1351GE	1800	Prime	293	312	0,93	272	341
::	1800	St-By	323	342	0,93	300	375
TAD1352GE	1800	Prime	344	363	0,93	320	400
::	1800	St-By	376	395	0,93	350	437
TAD1353GE	1800	Prime	391	410	0,93	364	455
::	1800	St-By	430	449	0,93	400	500
Power Factor		0,8					

SoD w804

SoD w804

SoD w824

SoD w824

Tier 3 – US
 1800 rpm only
 2008 Q0-2

Base engine

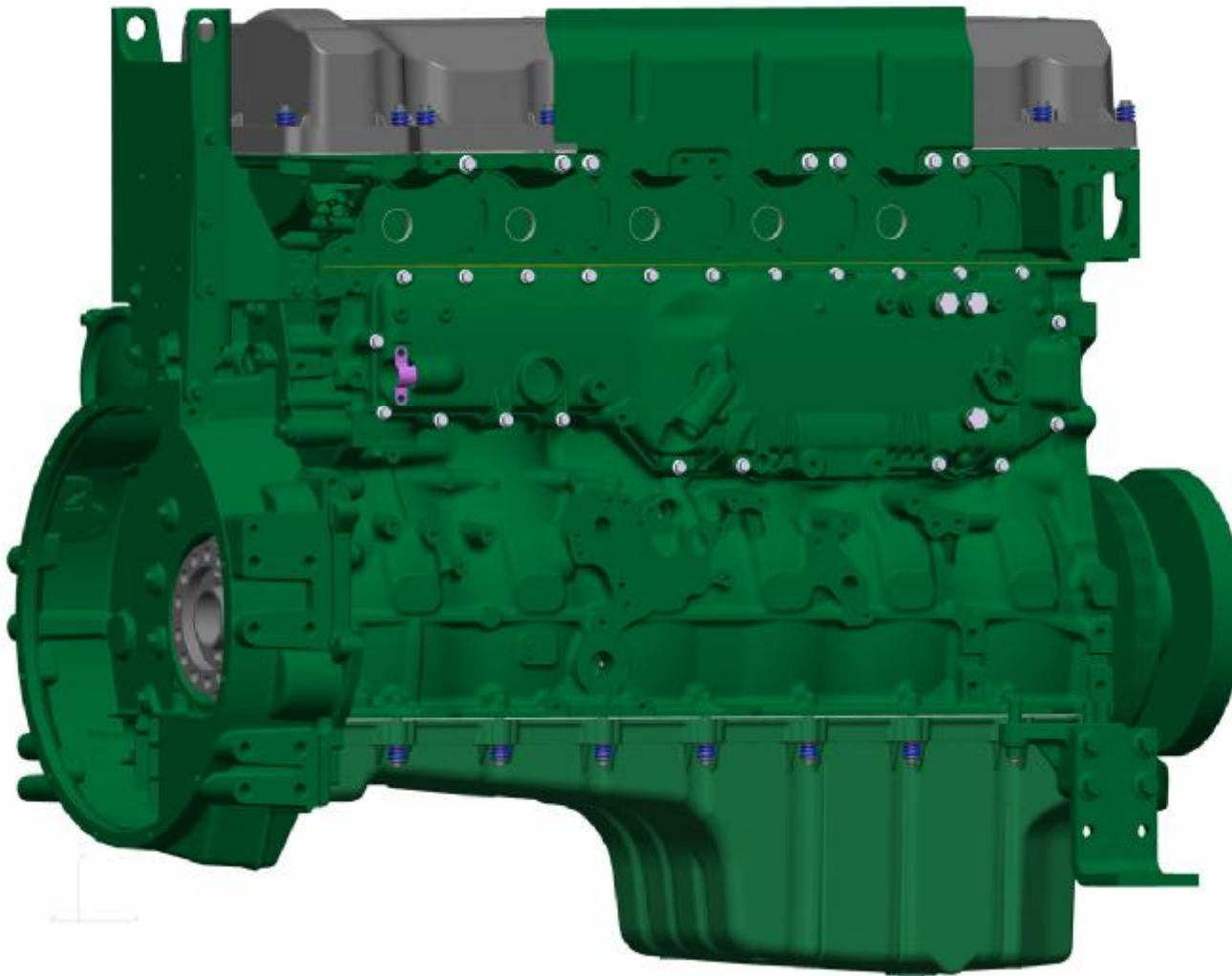

- Rear transmission
- Piston VPT Steel
- Camshaft
iEGR on/off by VEB6
Miller 560
Ceramic rollers
- Unit Injectors (Delphi 3.18)

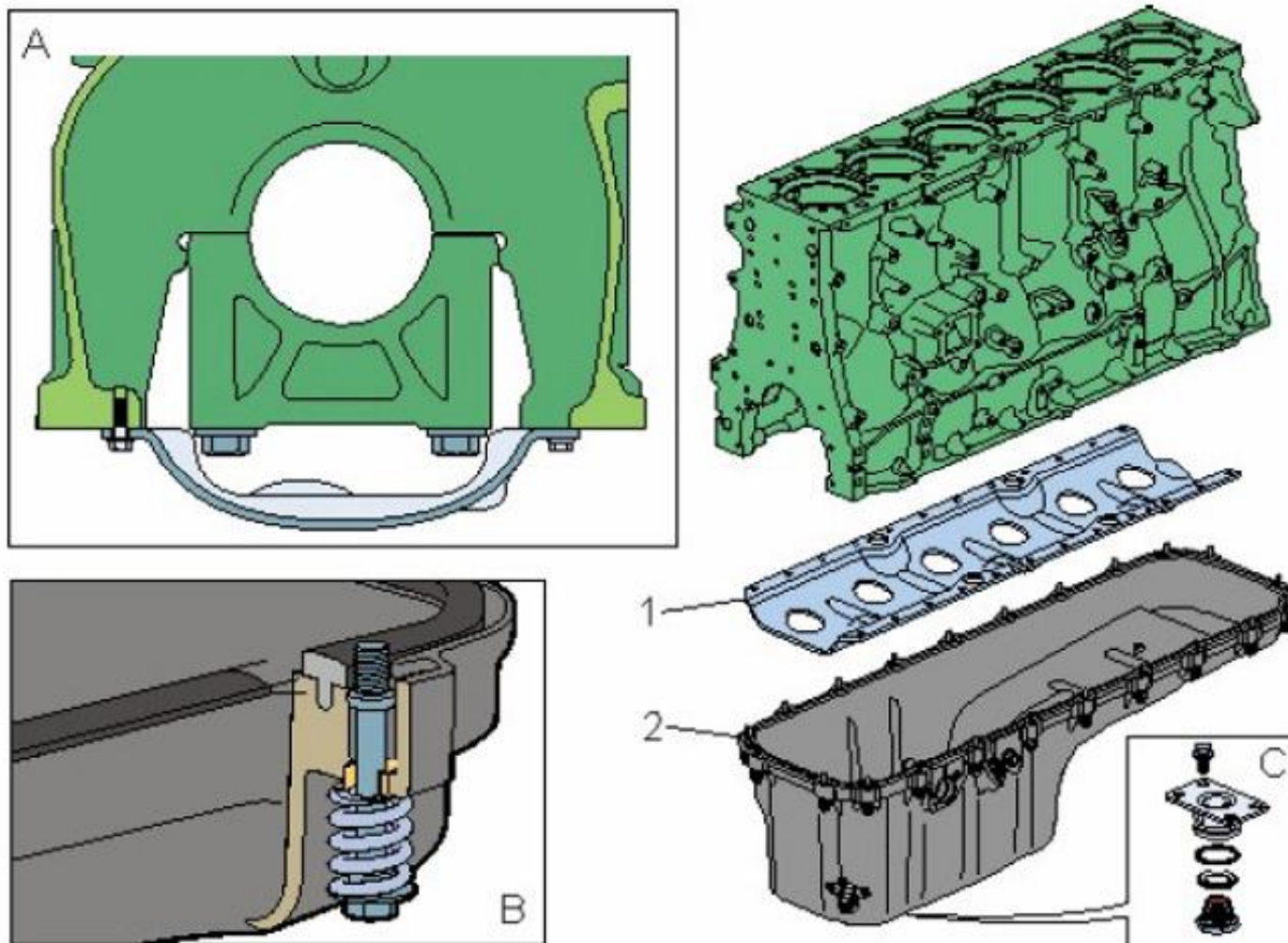

VP-SSK-1234-A-EN

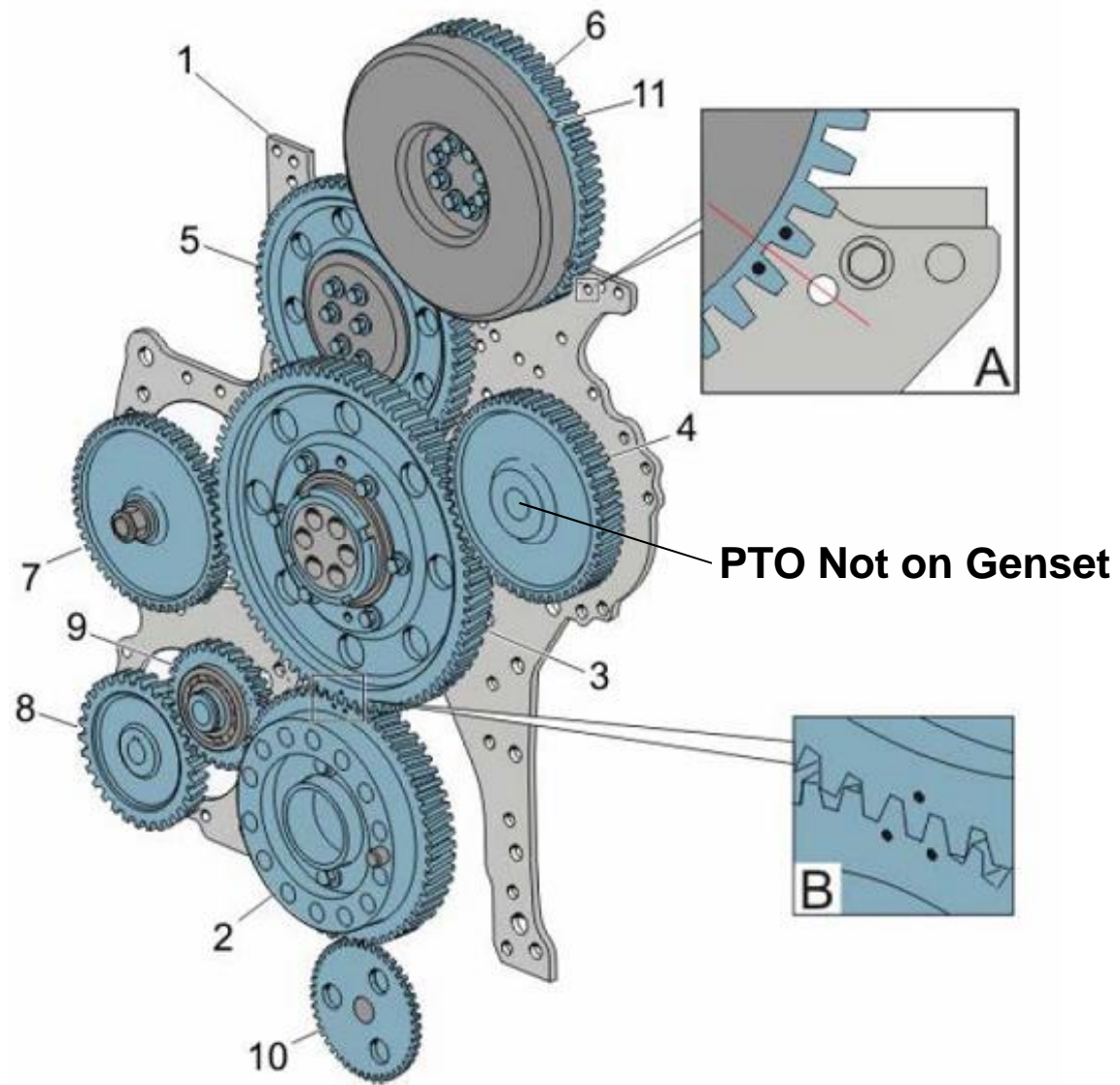

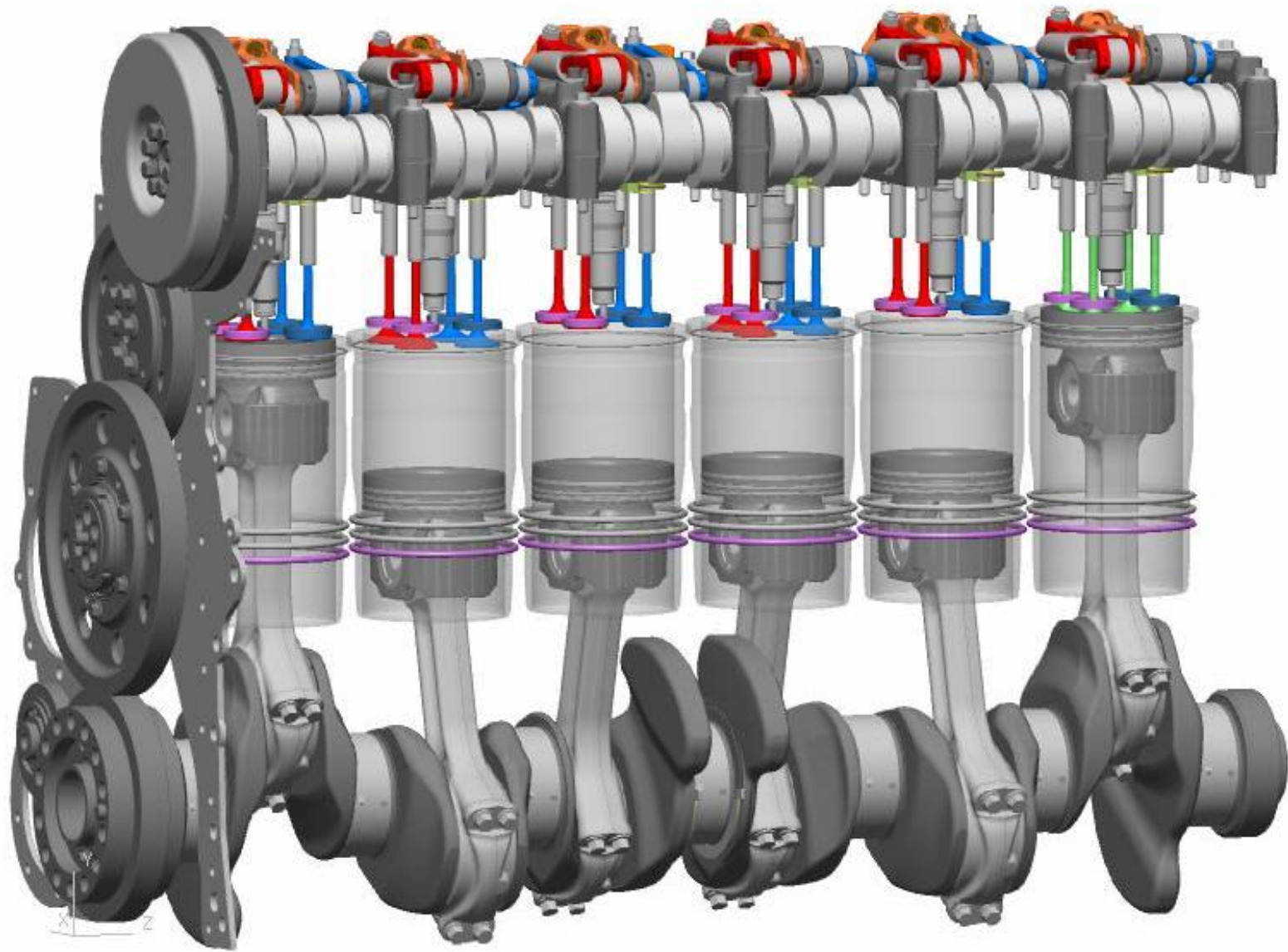

VP-SSK-1234-A-EN

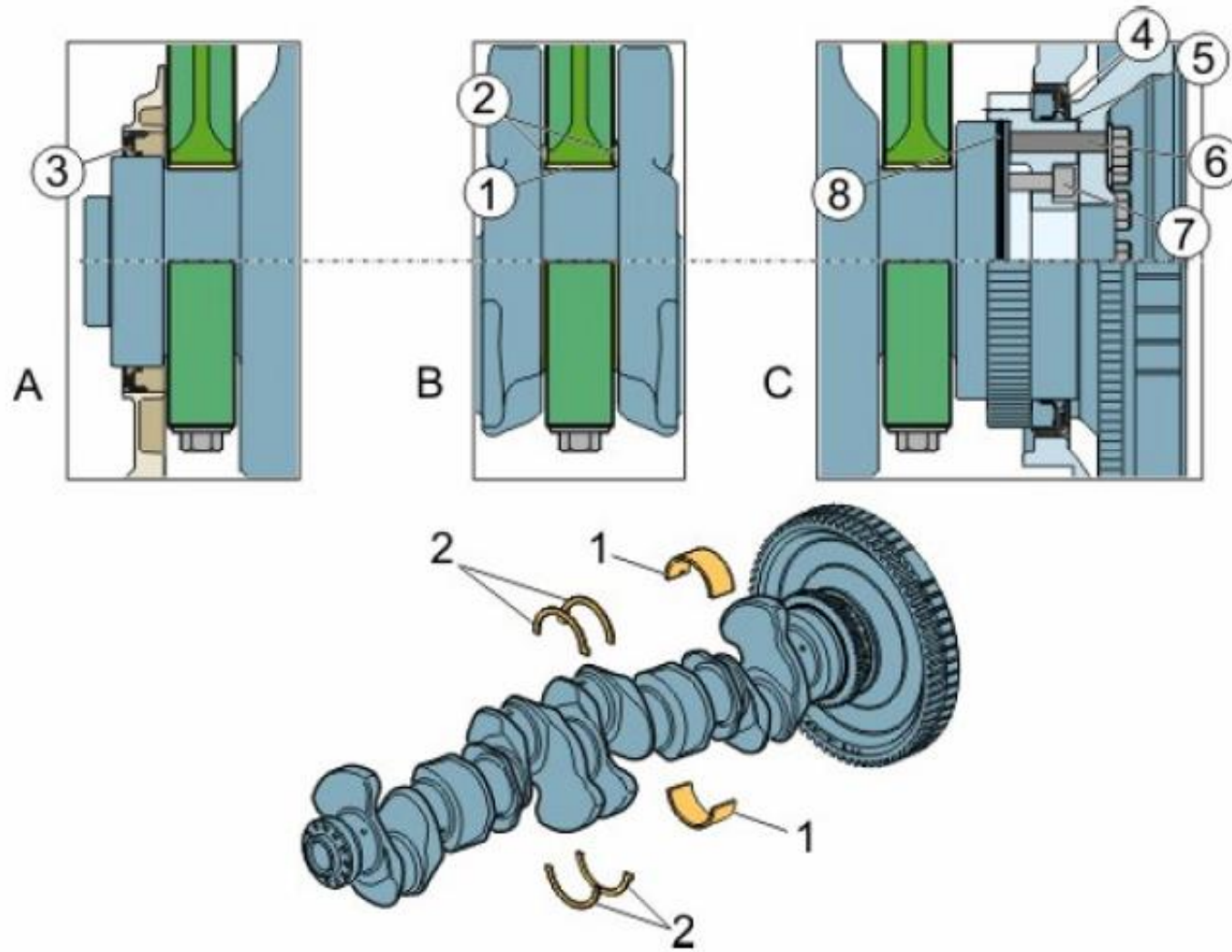

VP-SSK-1234-A-EN

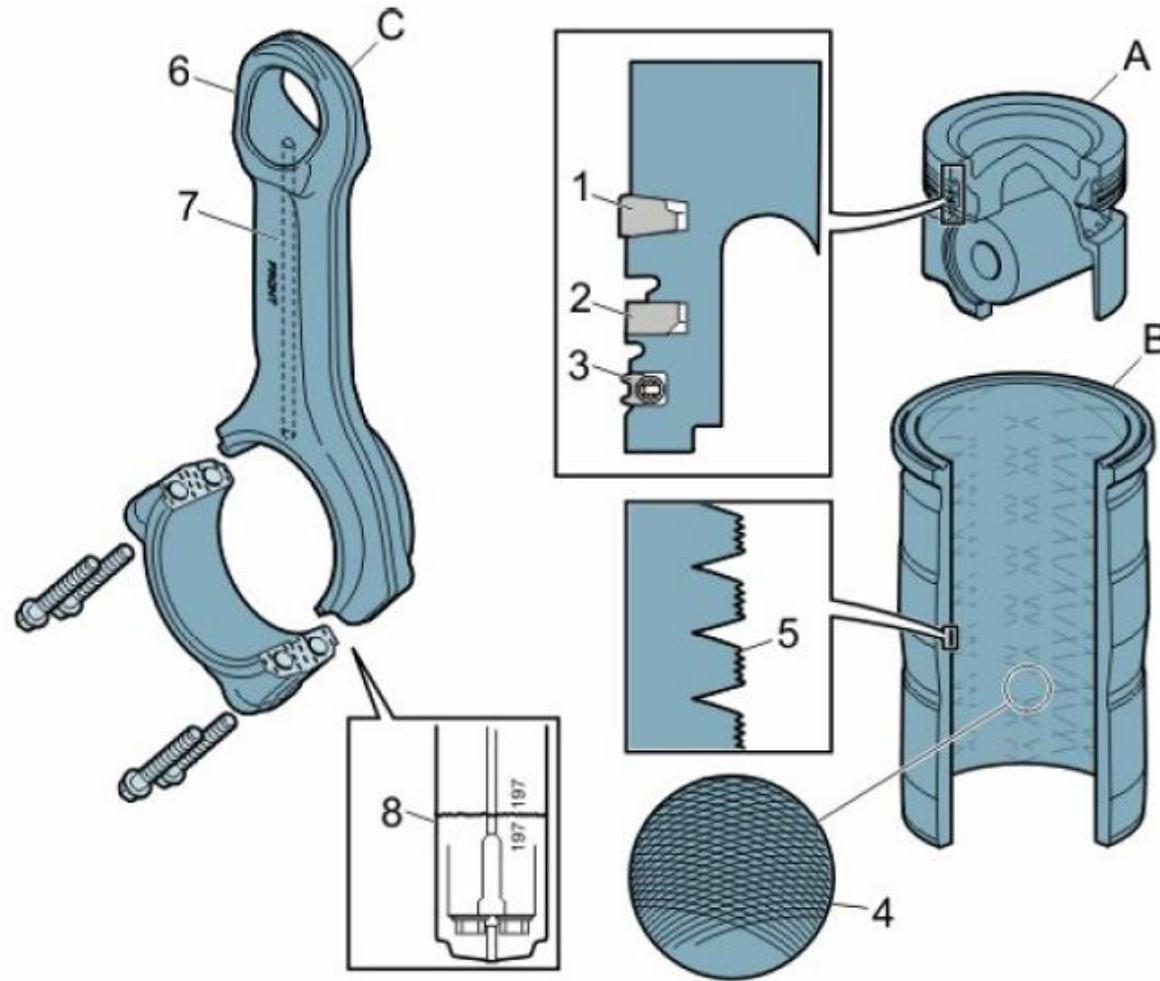

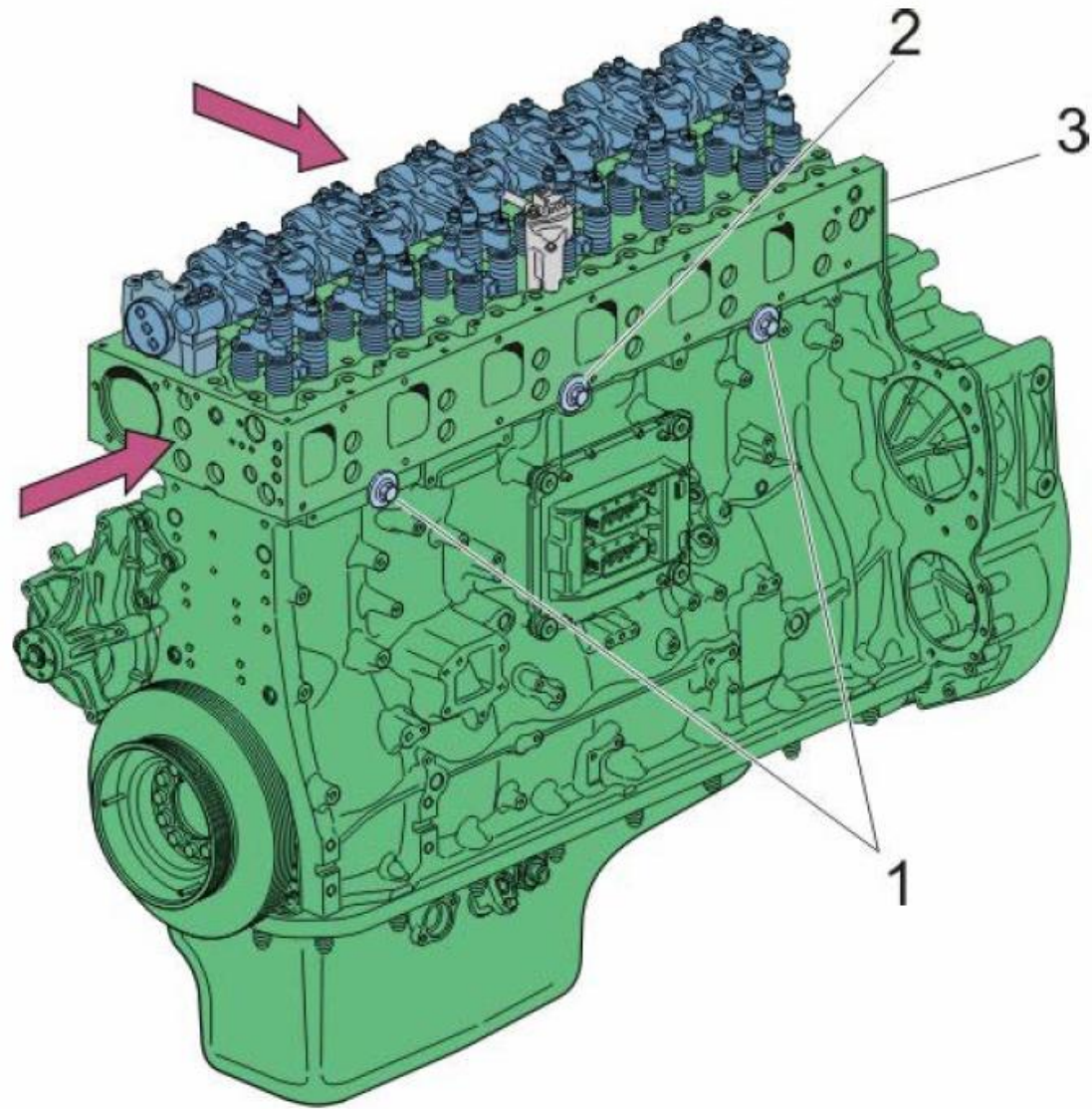

VP-SSK-1234-A-EN

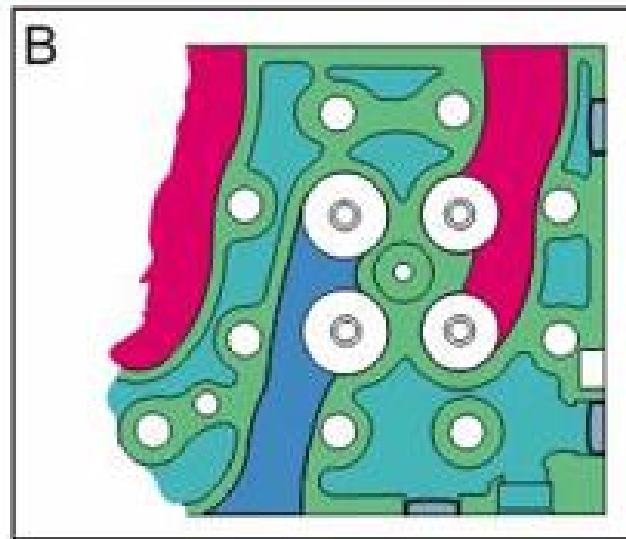
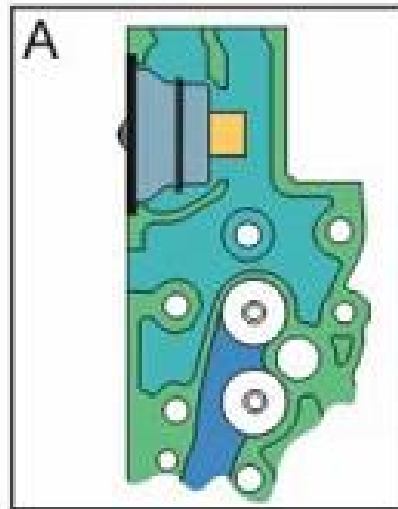
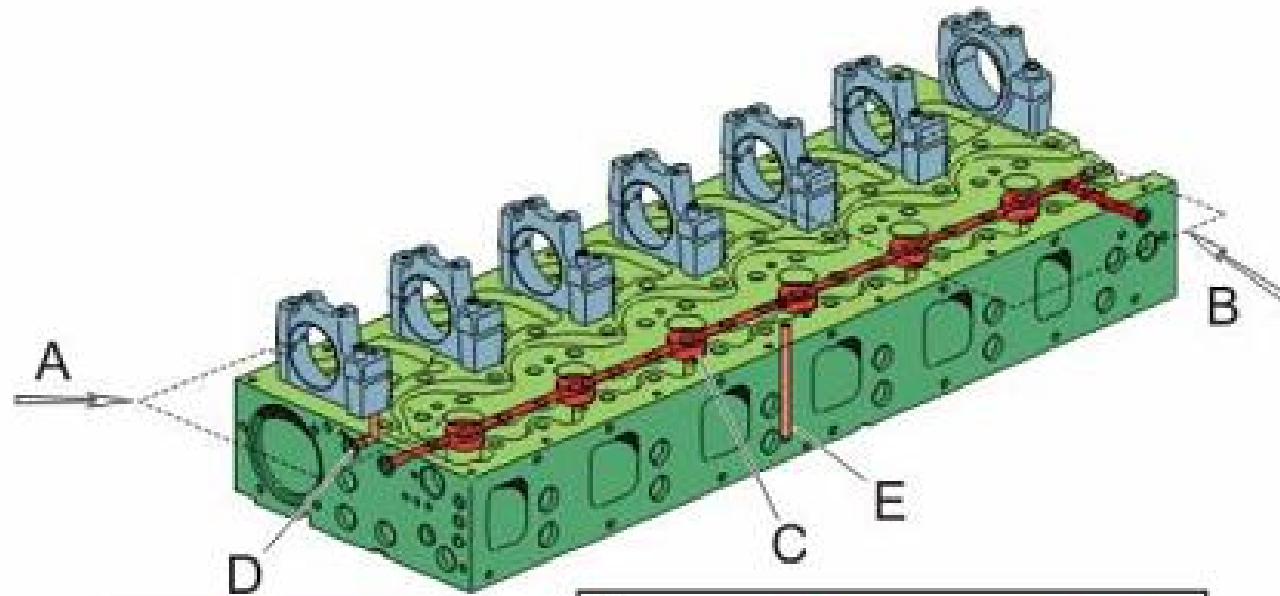

VP-SSK-1234-A-EN

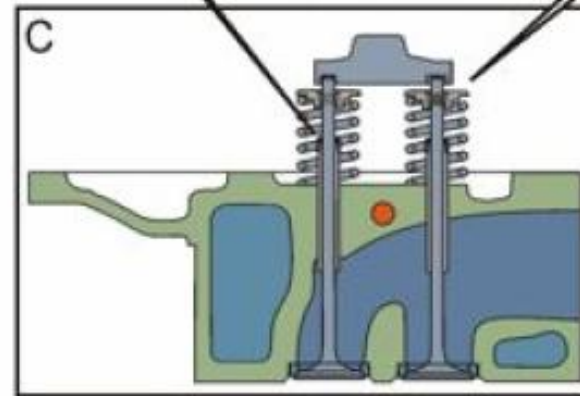
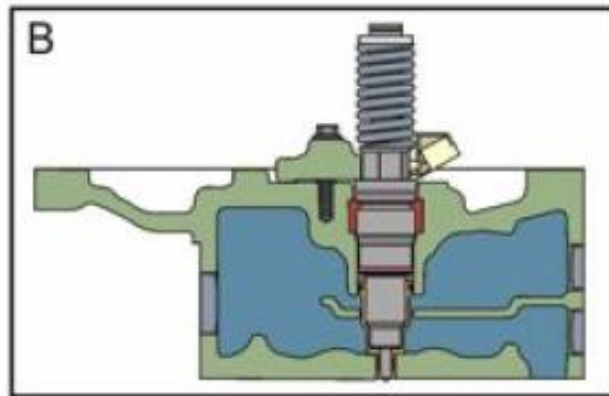
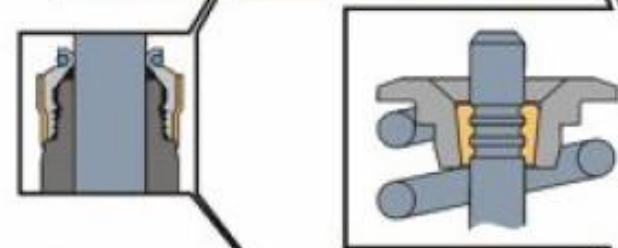
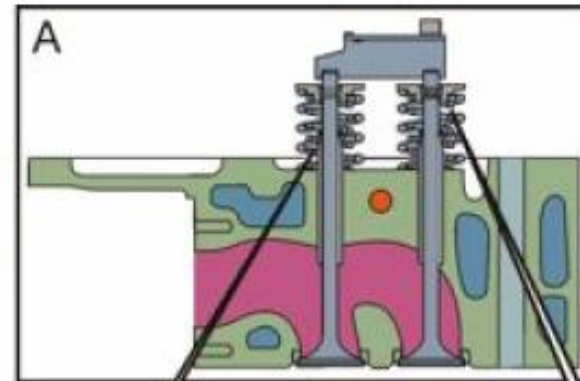
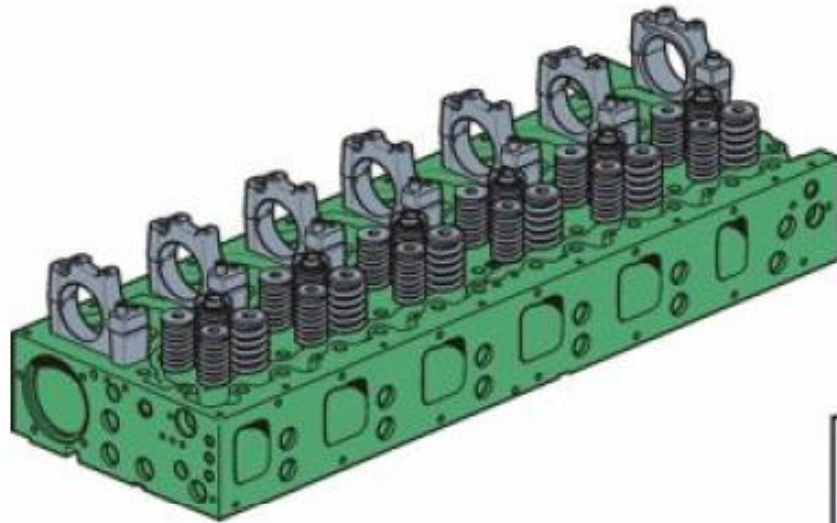

VP-SSK-1234-A-EN

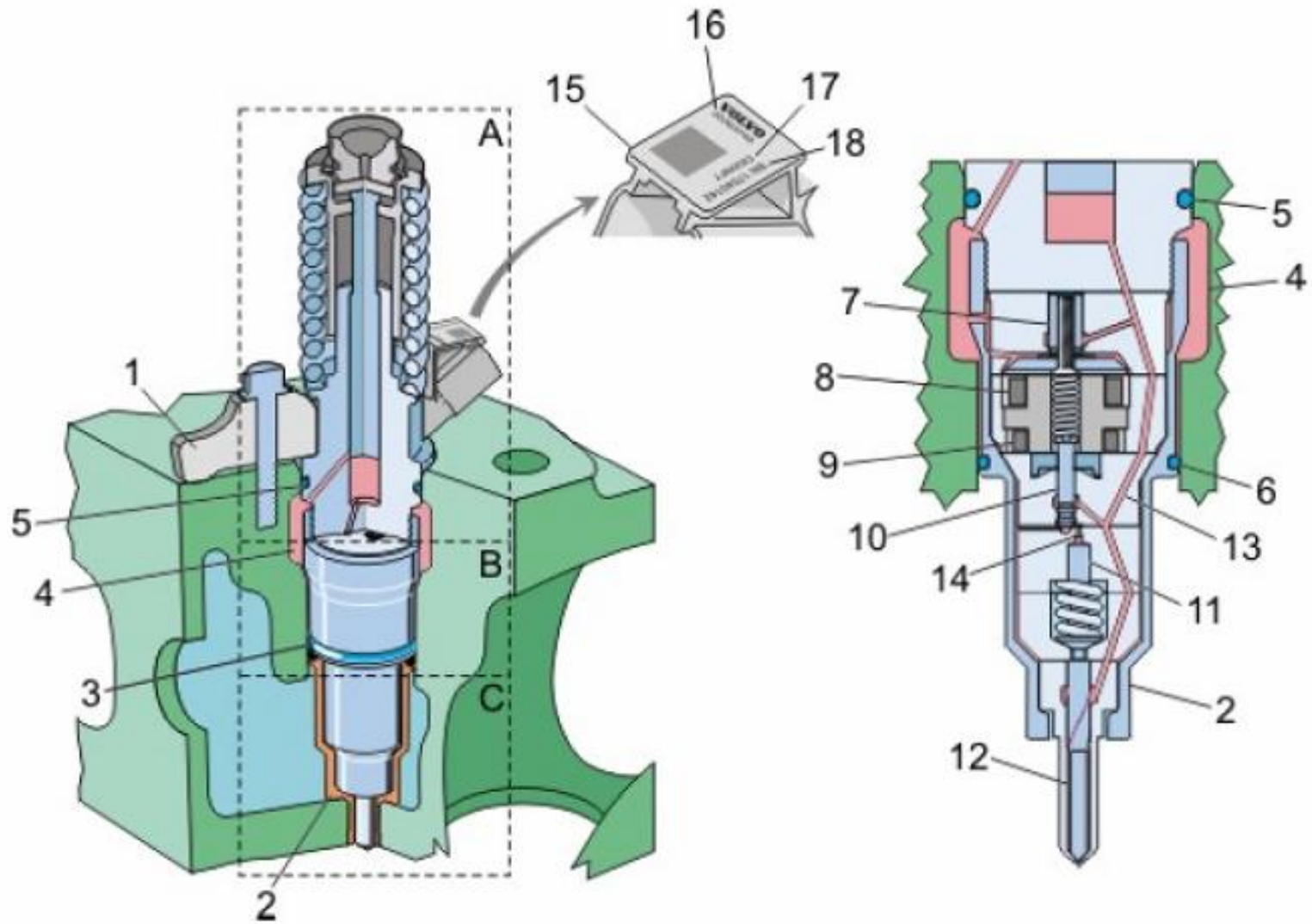

VP-SSK-1234-A-EN

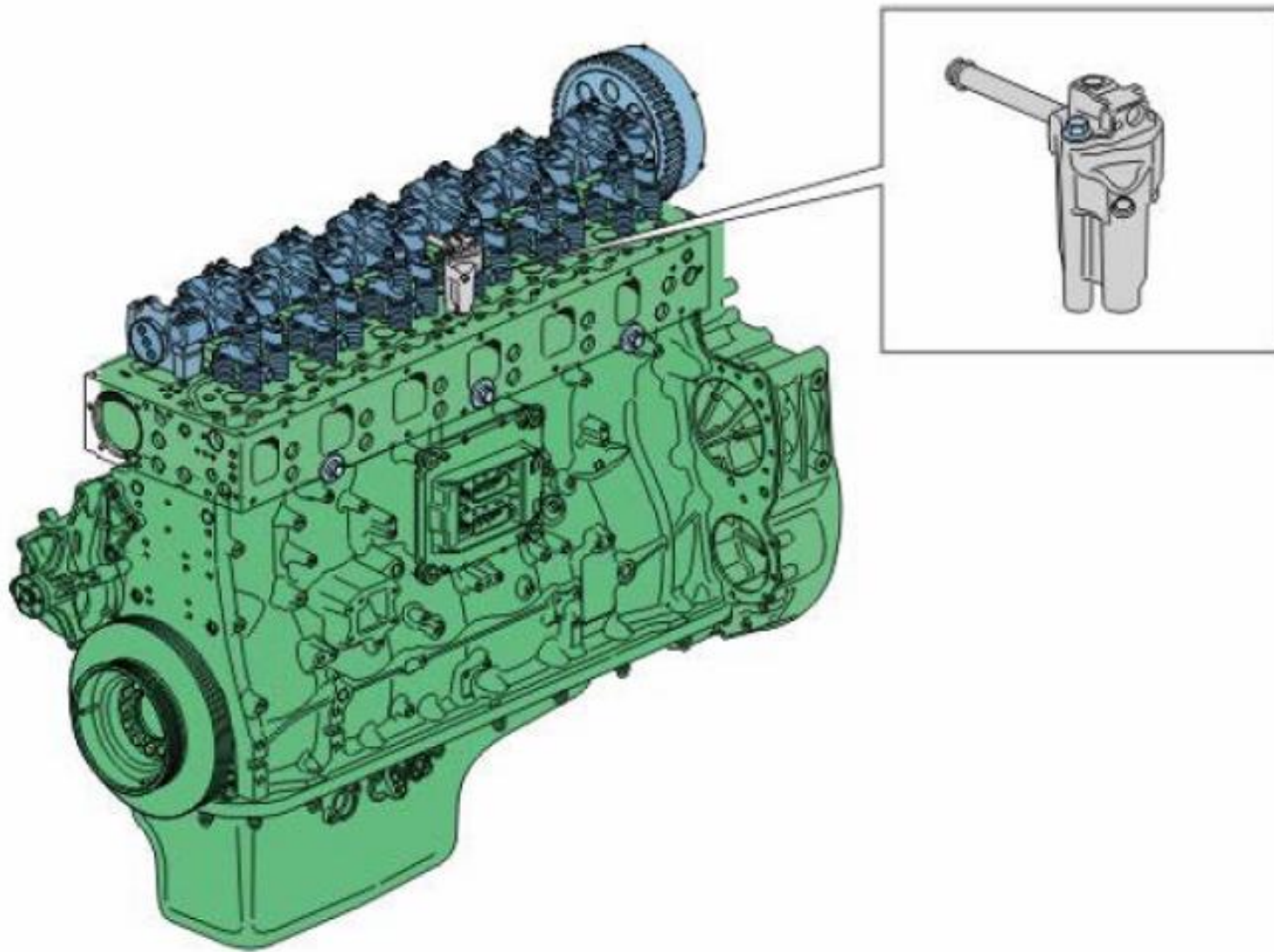

VP-SSK-1234-A-EN

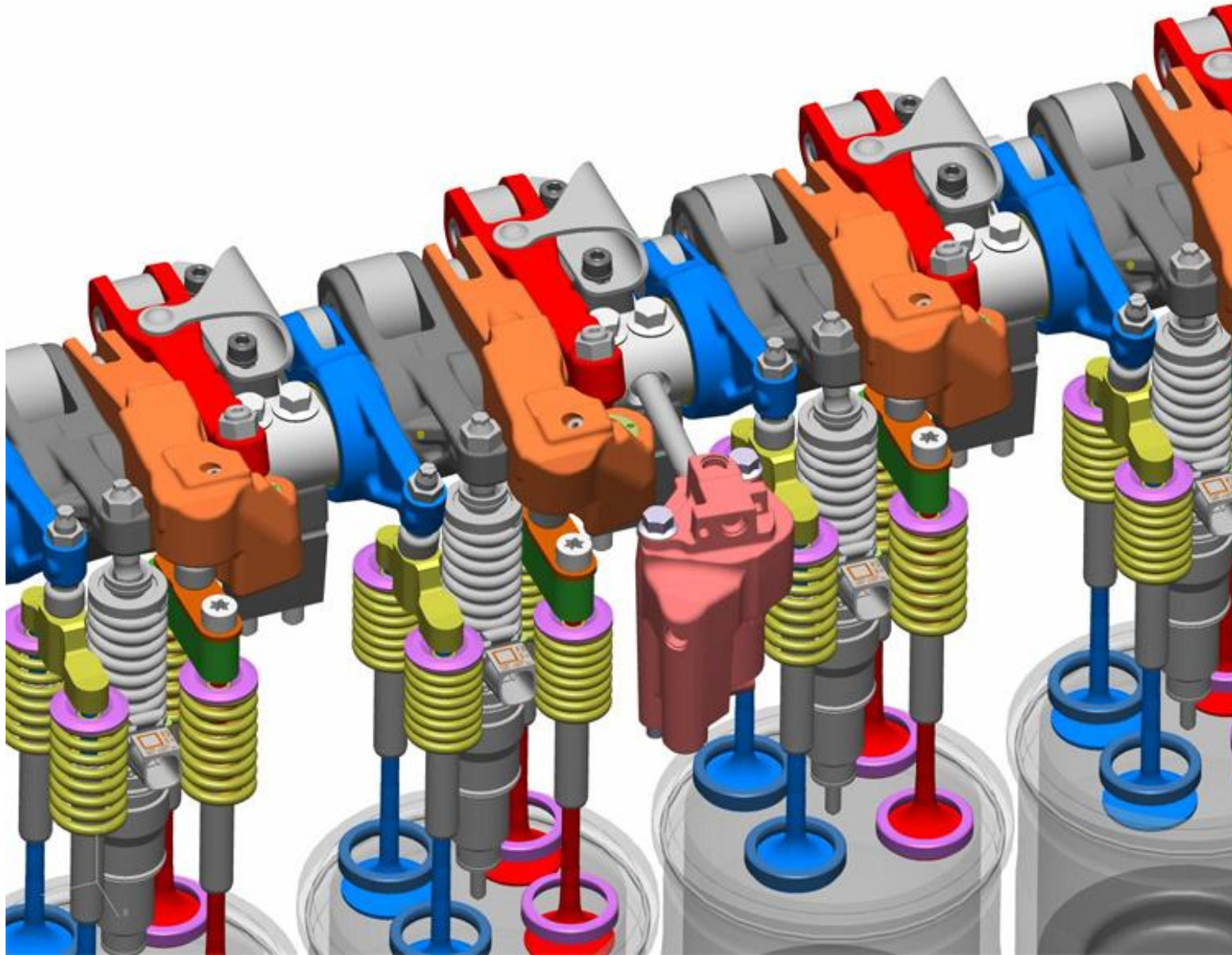

VP-SSK-1234-A-EN

IEGR

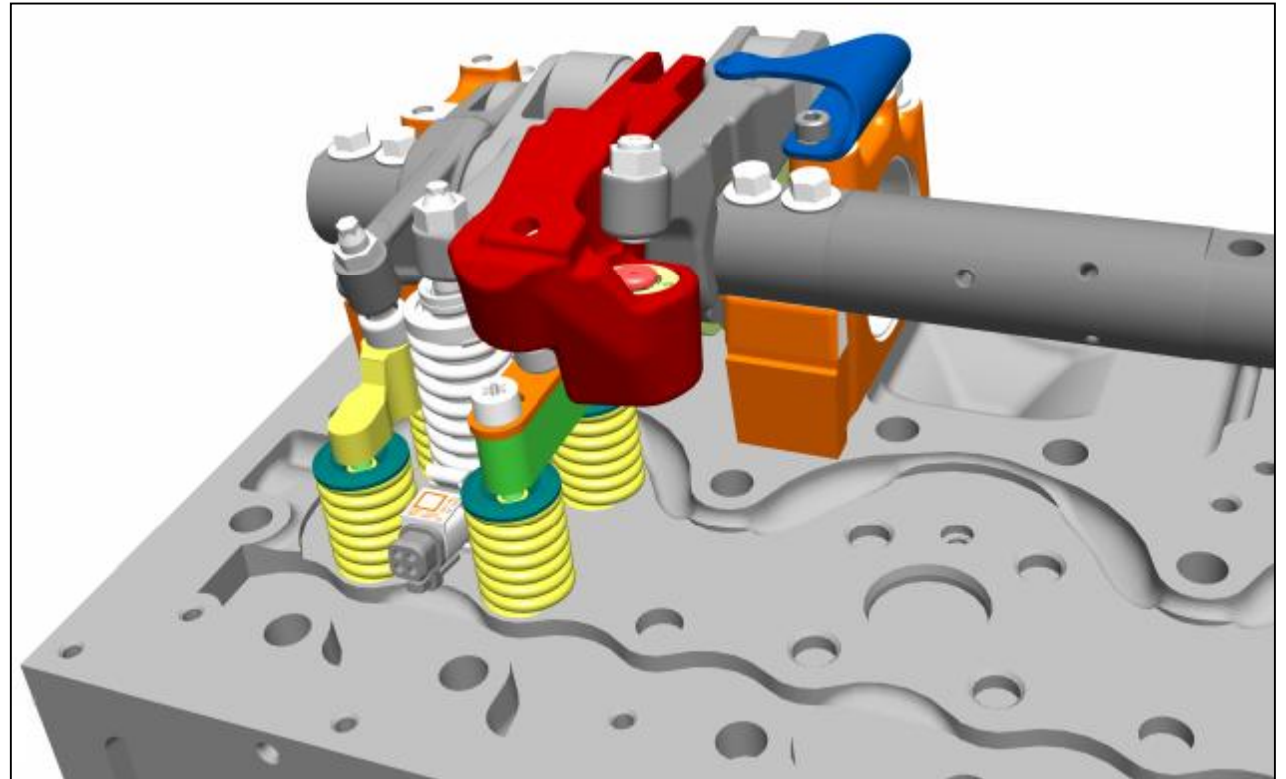
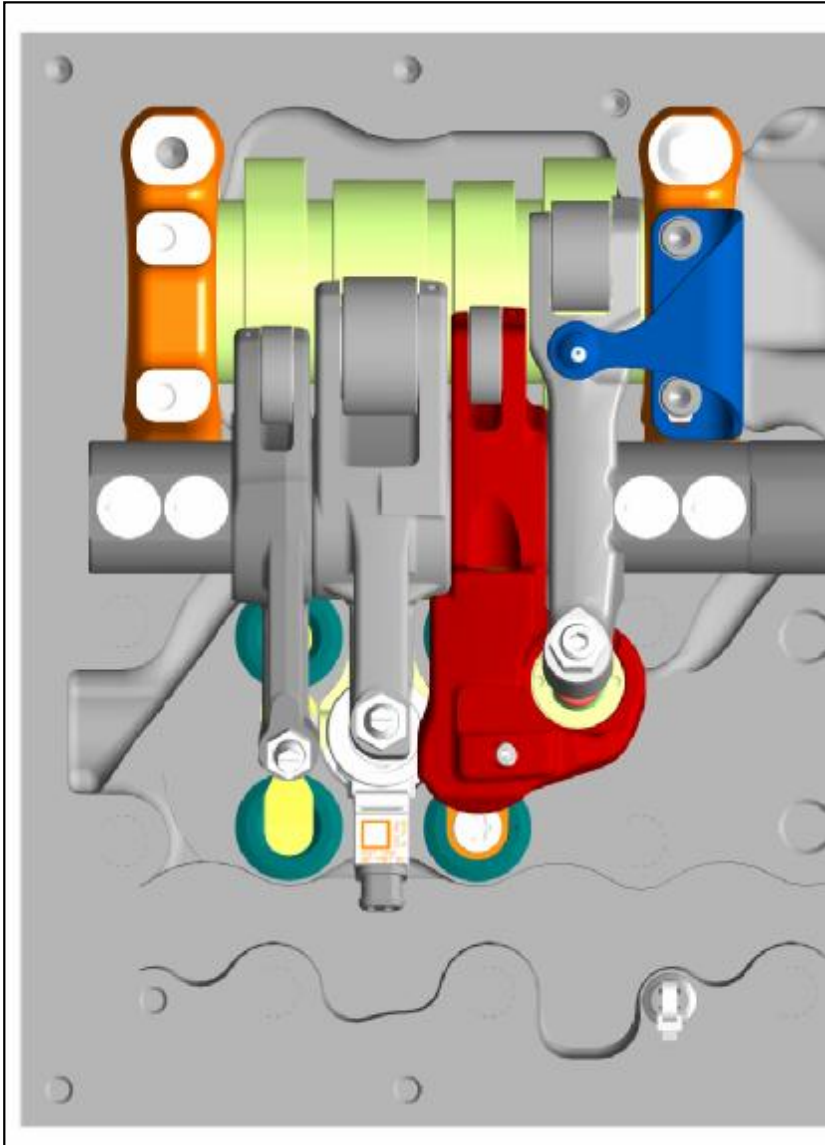

IEGR

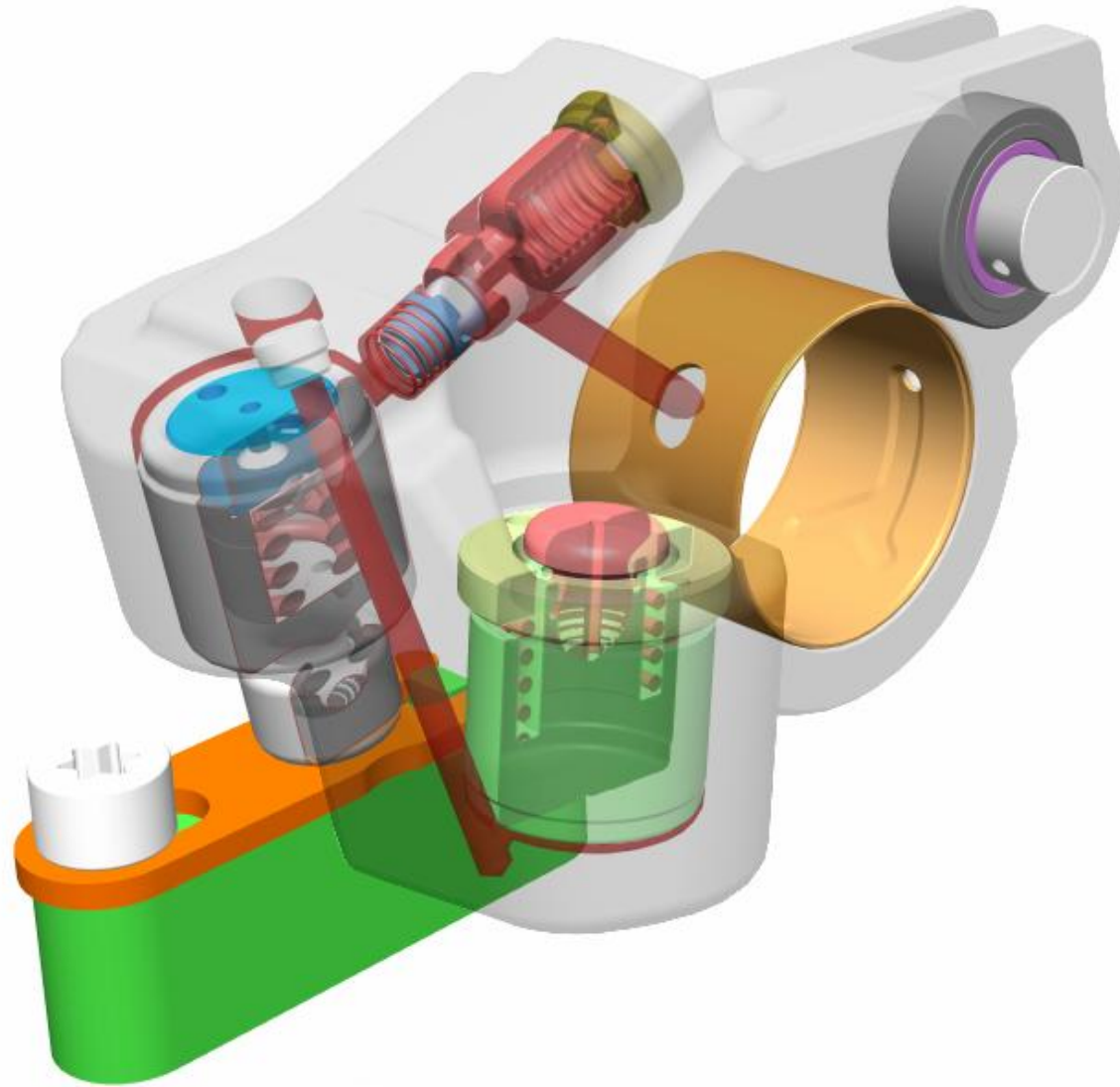

VP-SSK-1234-A-EN

Fuel system

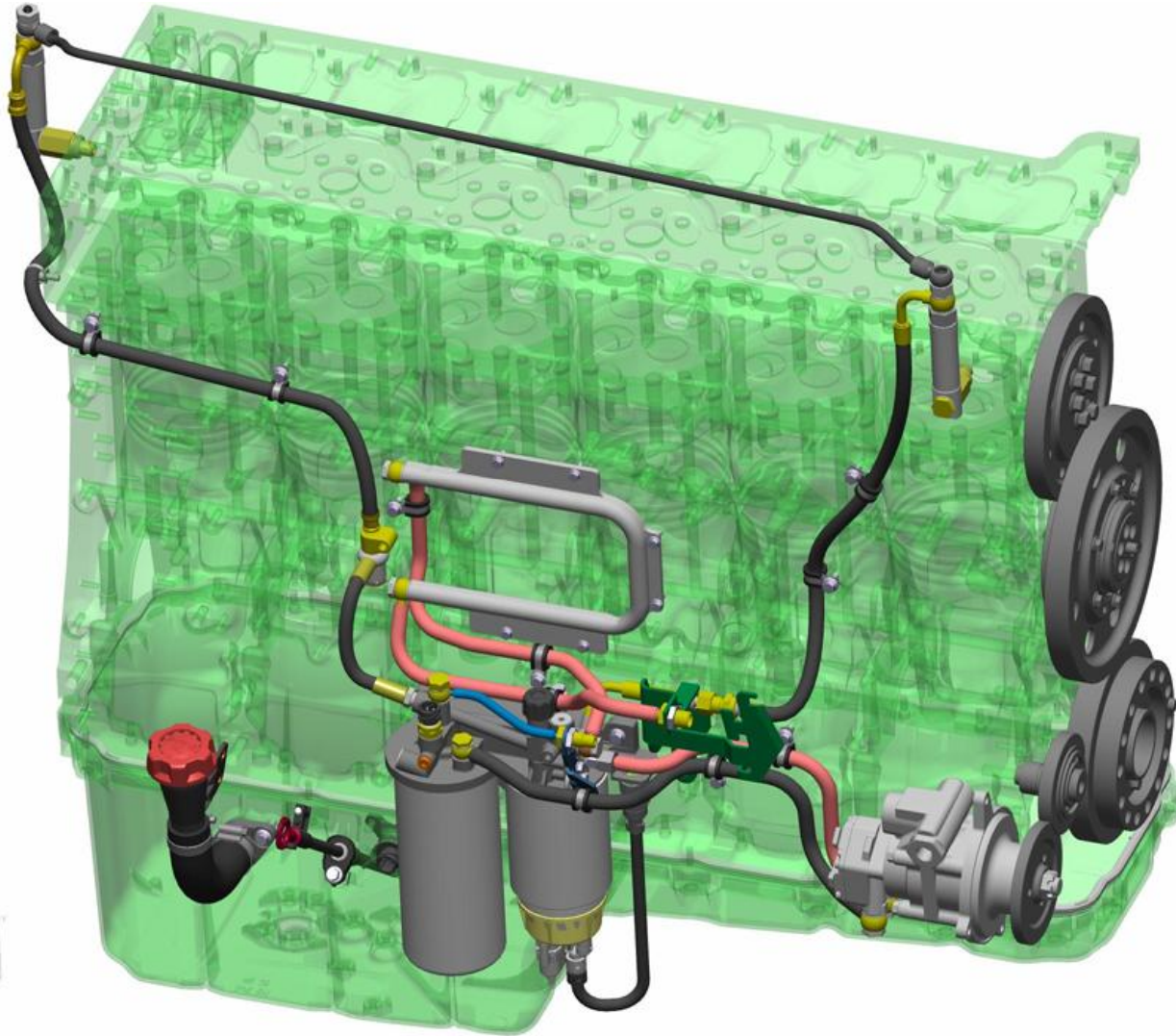

Fuel risers on cylinder head for startability matters.

Rubber mounted fuel filter console.
Decreases "air bubbles"

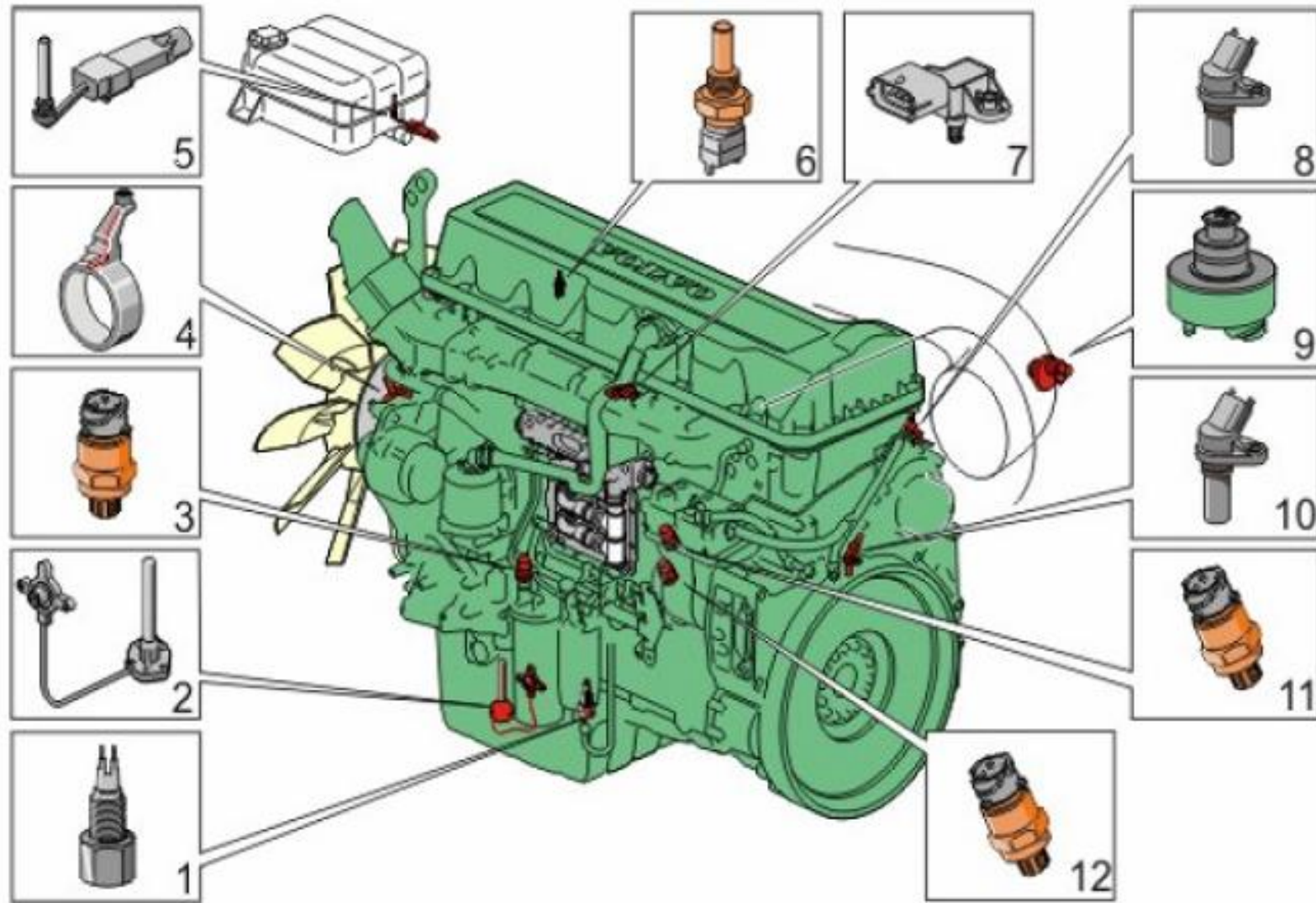

VP-SSK-1234-A-EN

Inlet & Exhaust system

MD-filter

STD-filter

Waste gate turbo
Electronically controlled by
PWM valve.

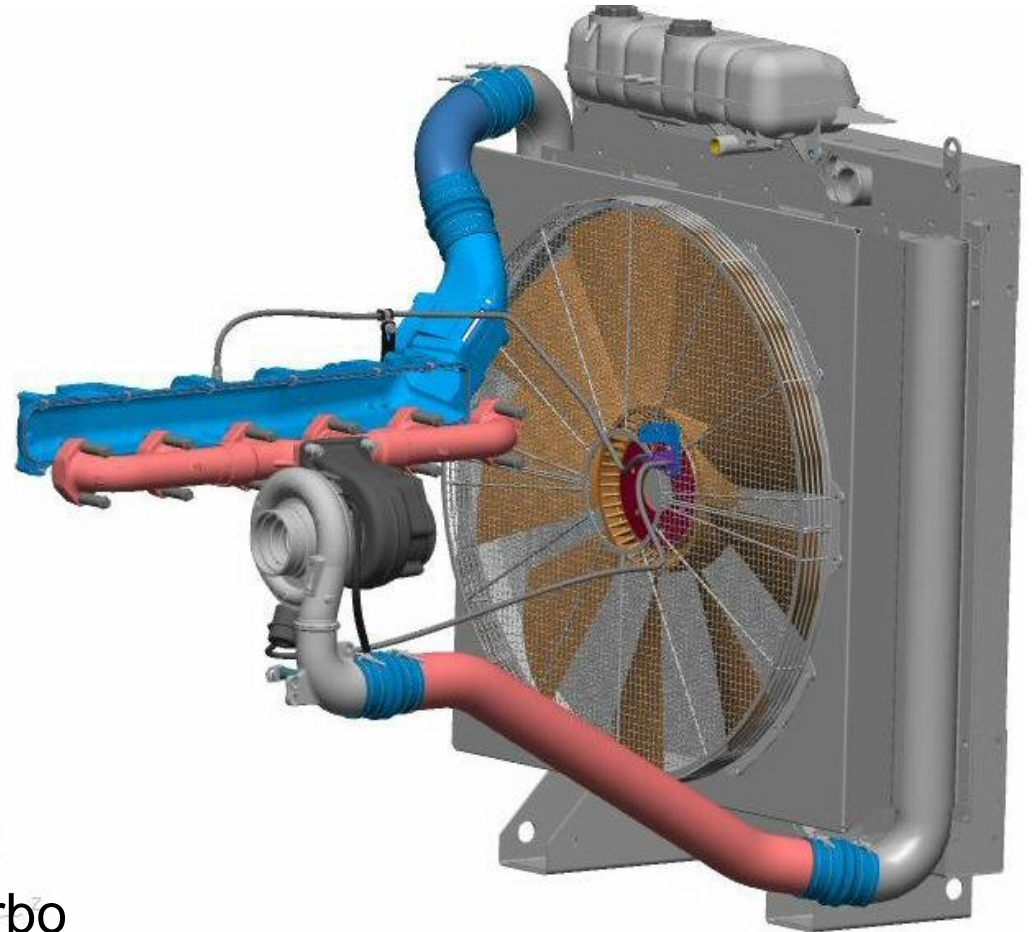
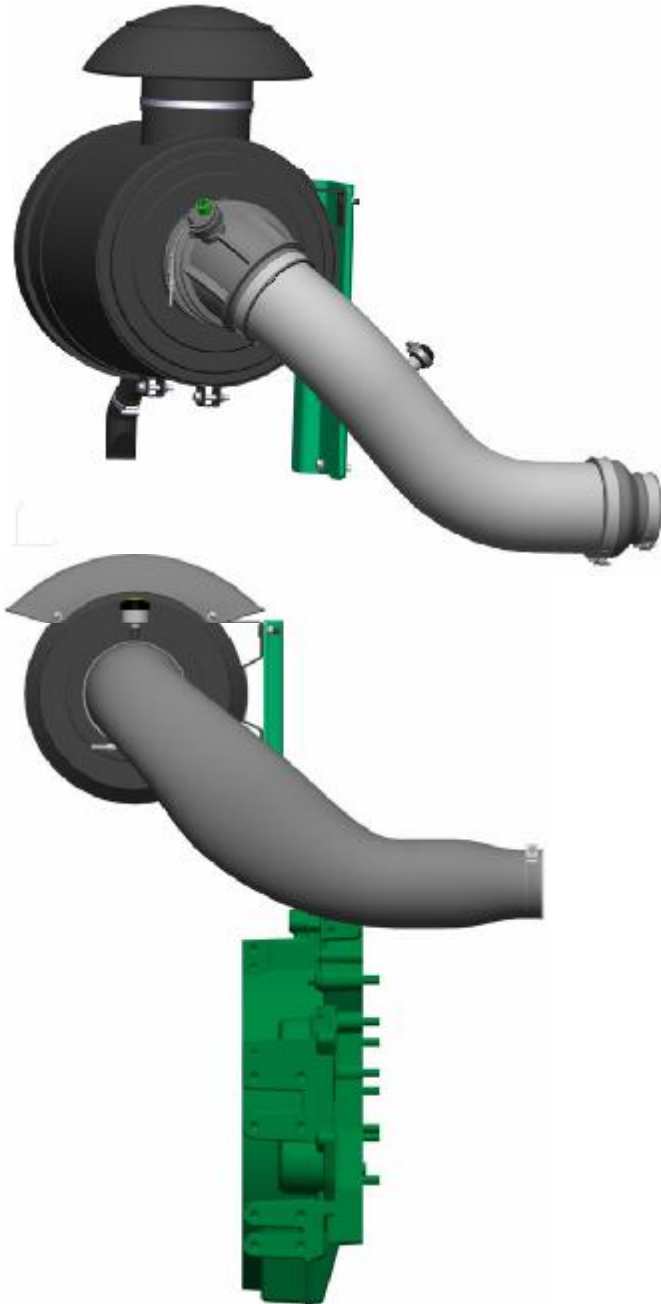

Crank case ventilation

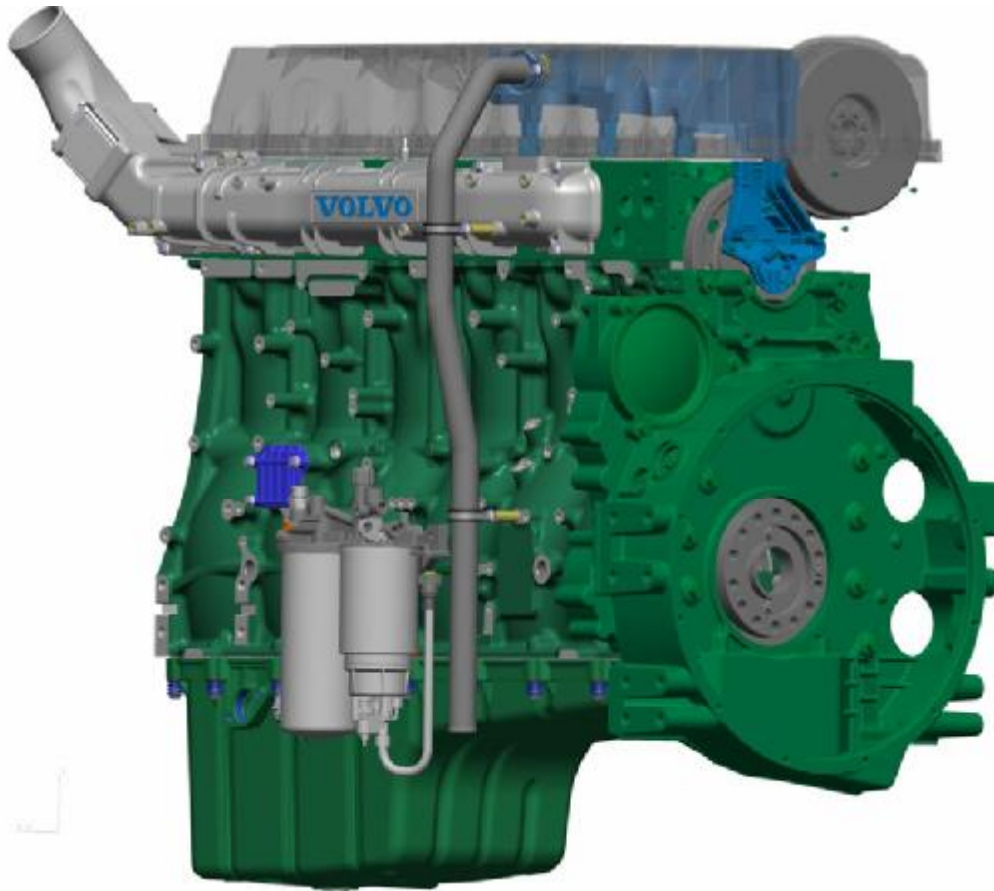

Standard
Open with oil traps in
transmission and valve cover

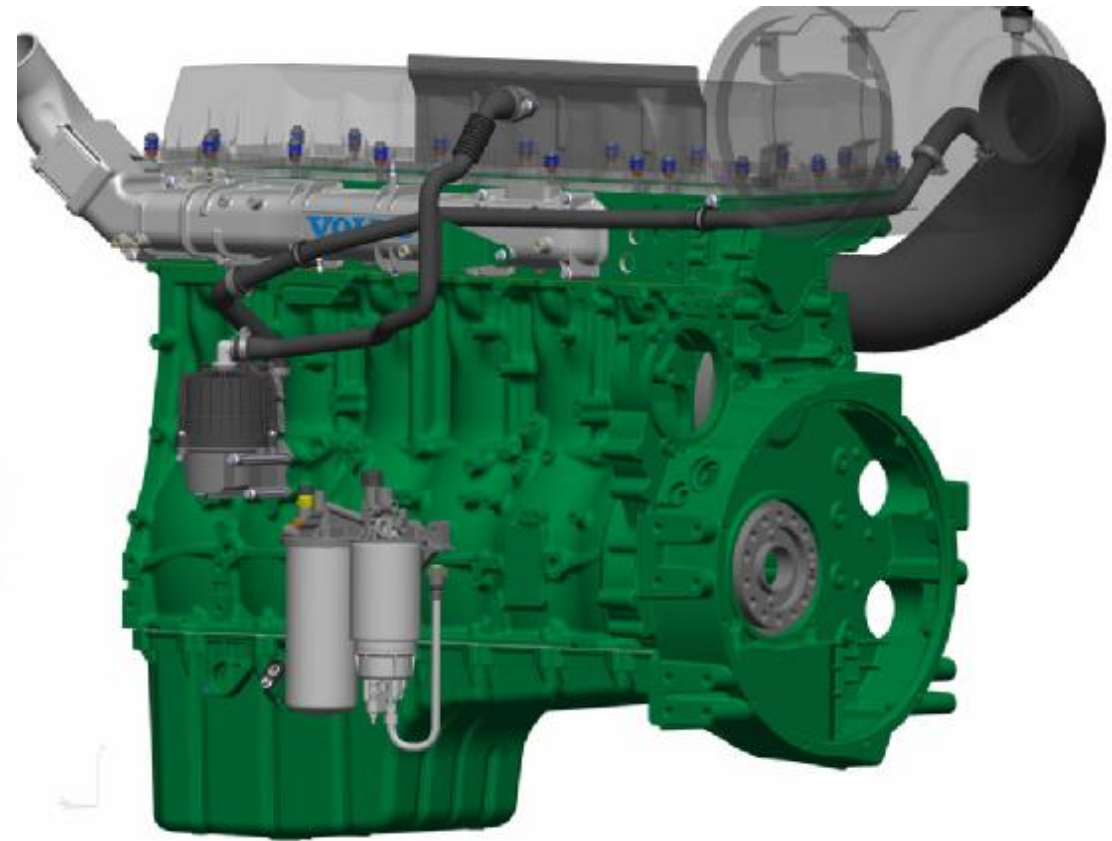

Optional
Closed with centrifugal oil separator

Coolant system

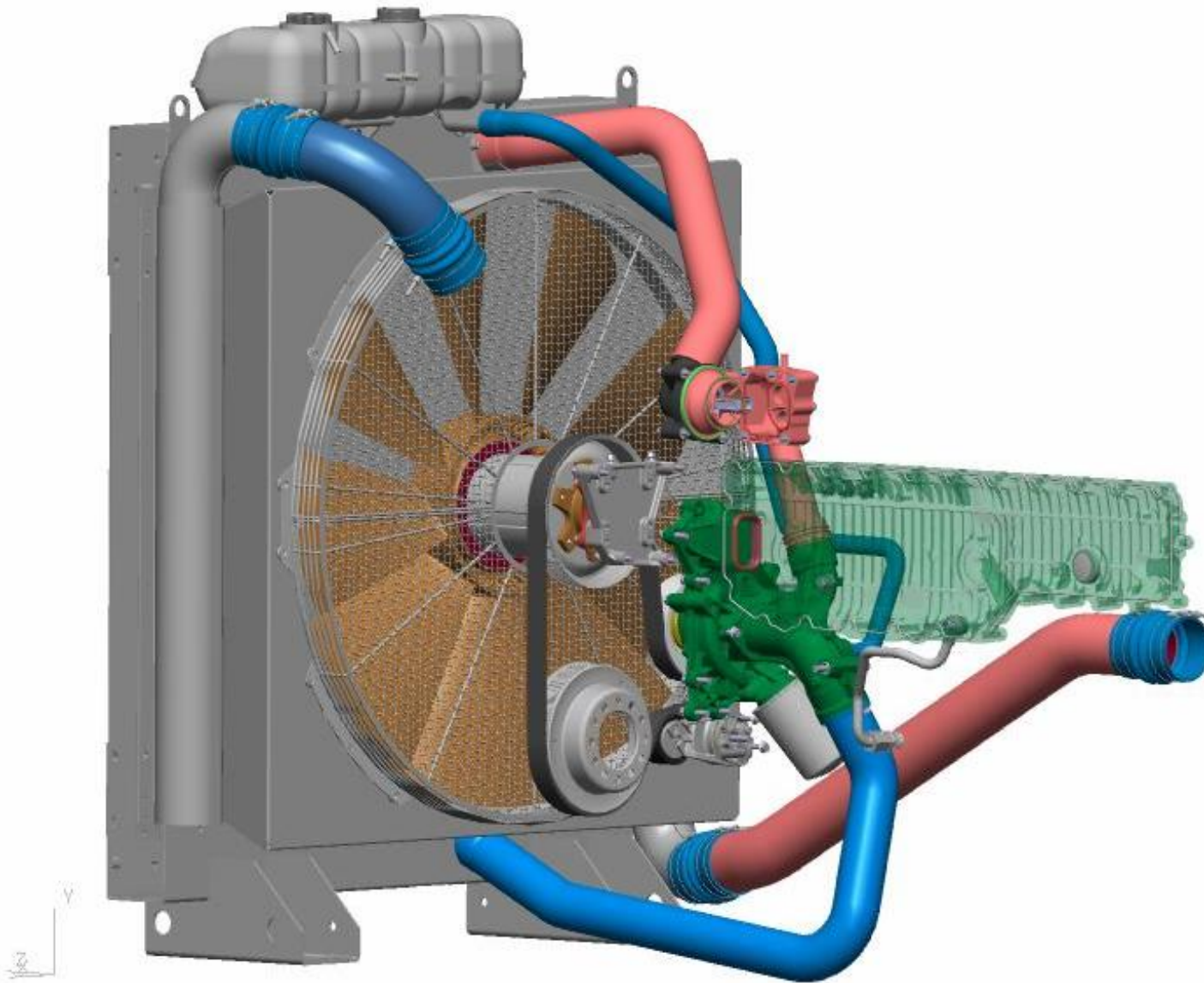

250-350 kWe

D12 cooling package TAD
AOT 56-62 (350)
AOT 64 & 69 (300 & 250)
Different fan-ratios
0,84 0,99 and 1,07
Thermostat – 82
Belt driven coolant pump.

400 kWe

D12 cooling package TAD
AOT 56-62
Different fan-ratios
0,84 0,99 and 1,07
Thermostat – 82
Belt driven coolant pump.
No iEGR used at 100% load
to minimize cooling req.

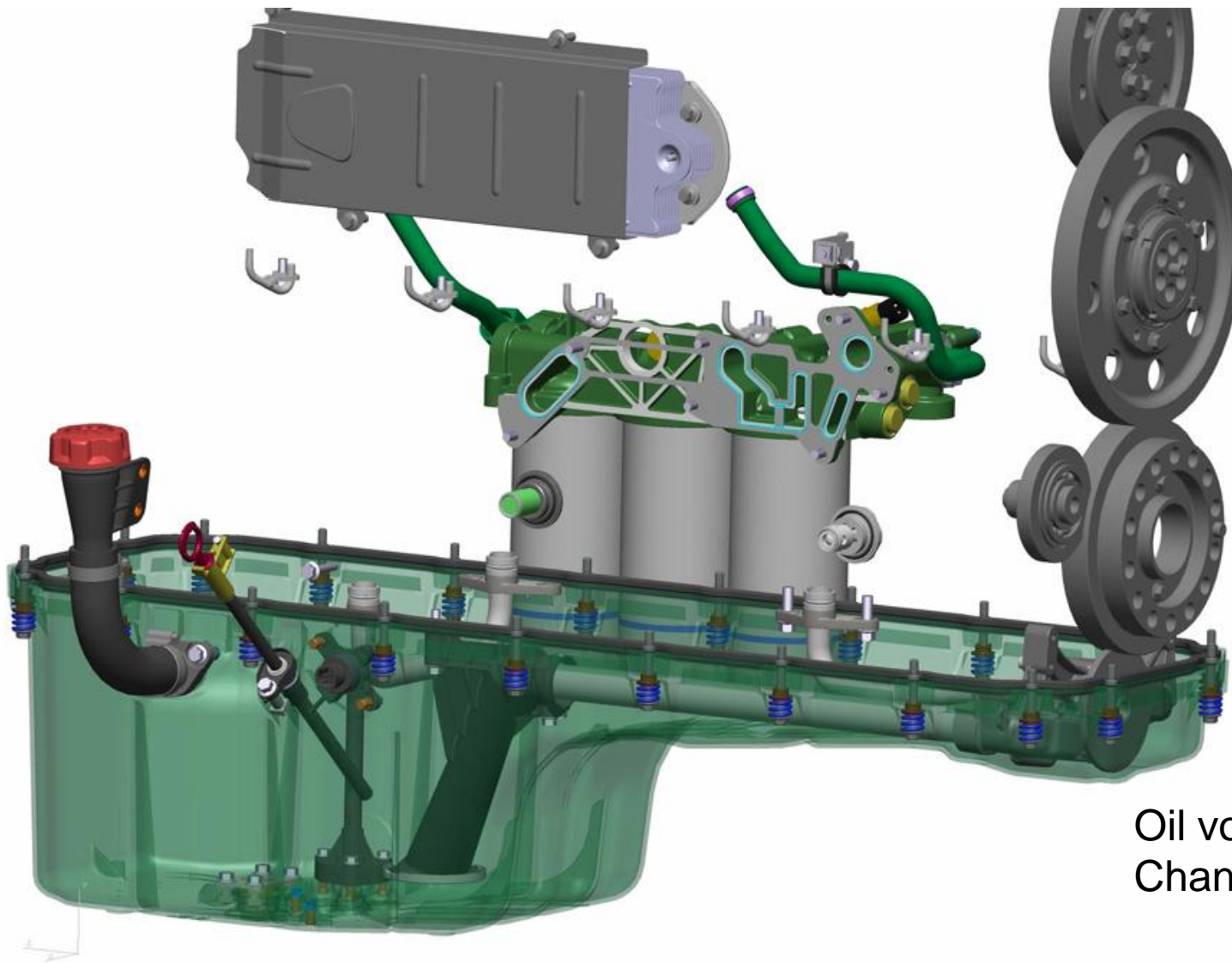

Oil volume	19-30l (Tot 36l)
Change interval	600h VDS 3
	400h VDS 2

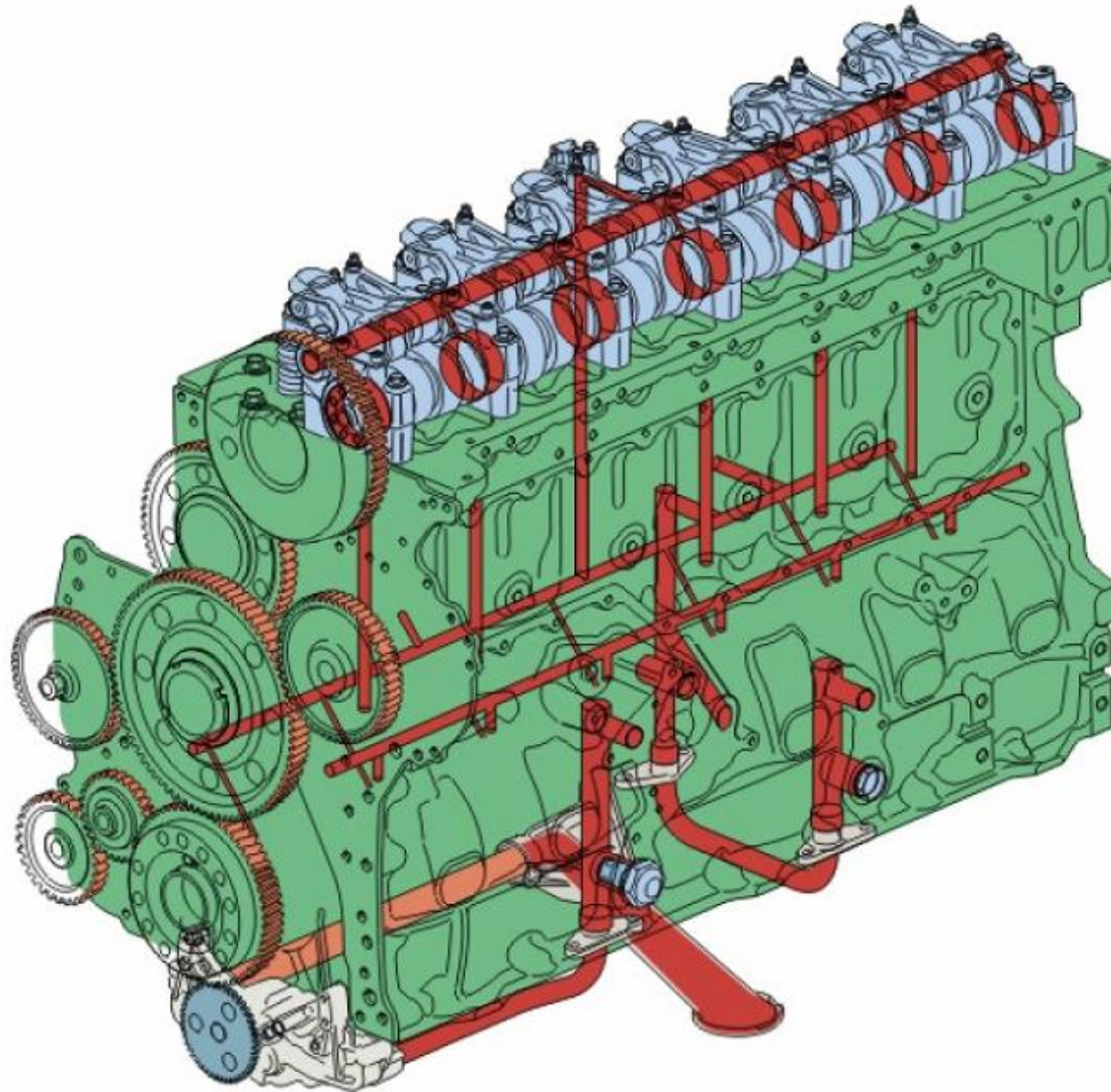

VP-SSK-1234-A-EN

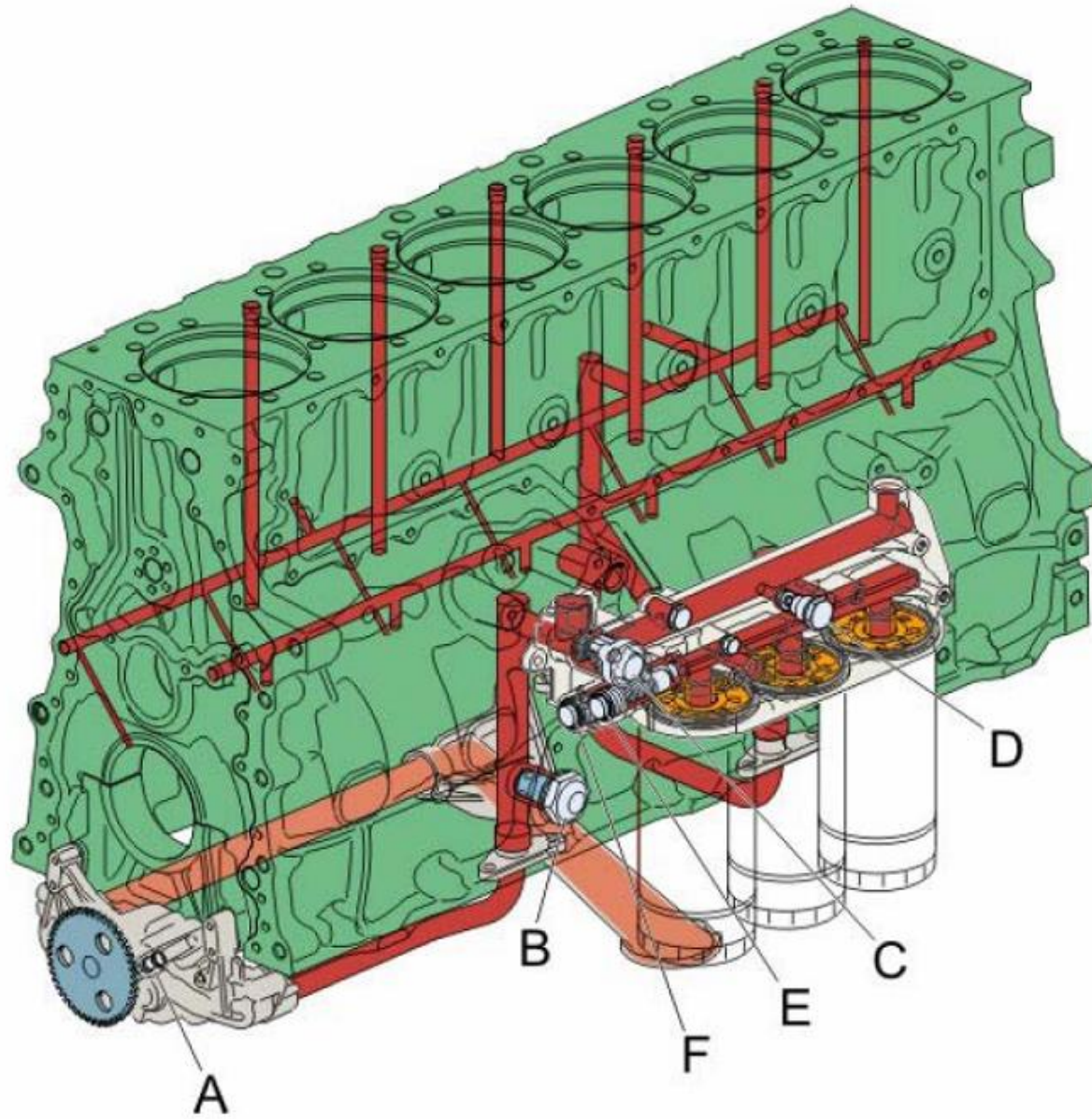

VP-SSK-1234-A-EN

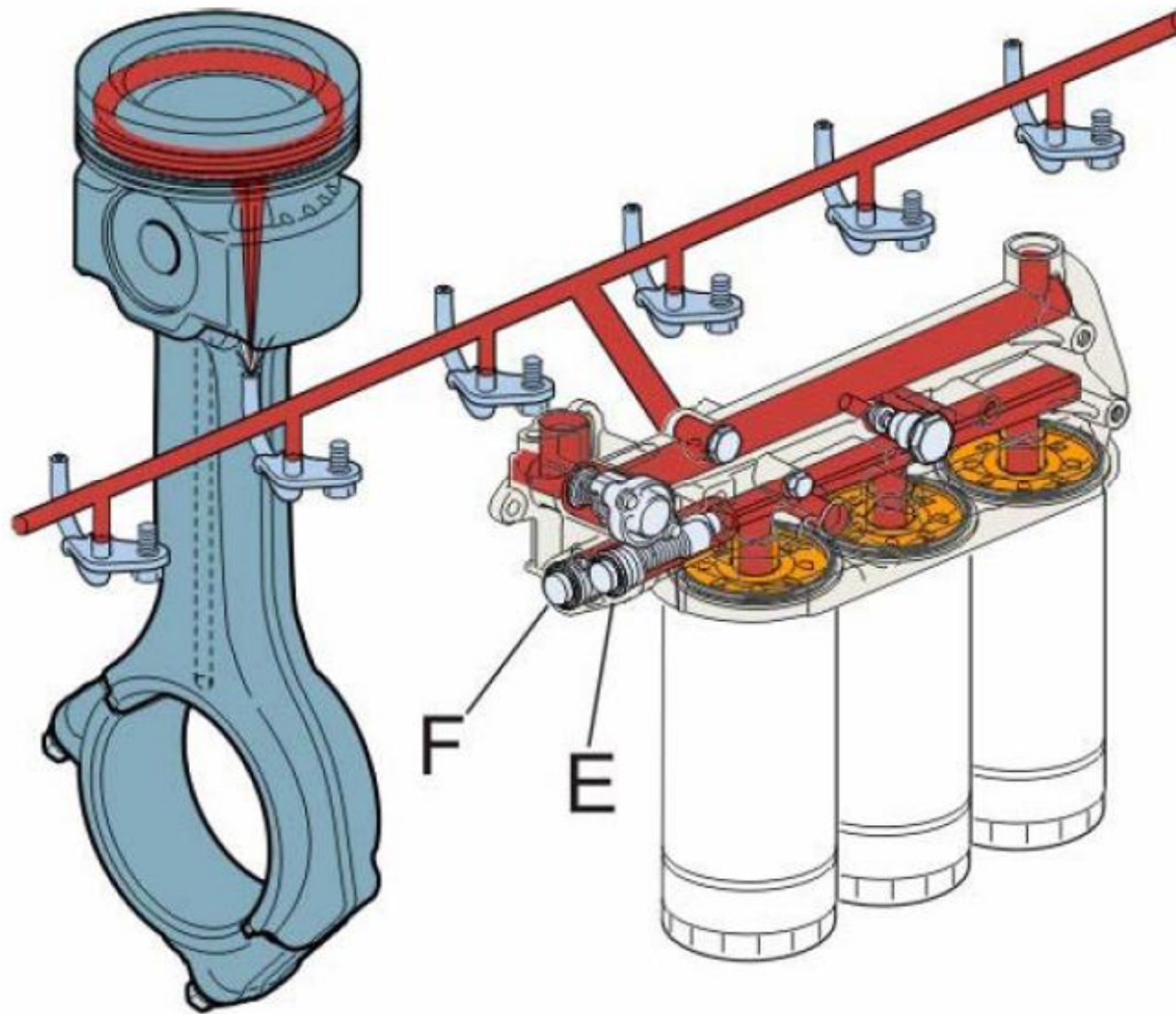

VP-SSK-1234-A-EN

Optional equipment Fan, belt & heatguard

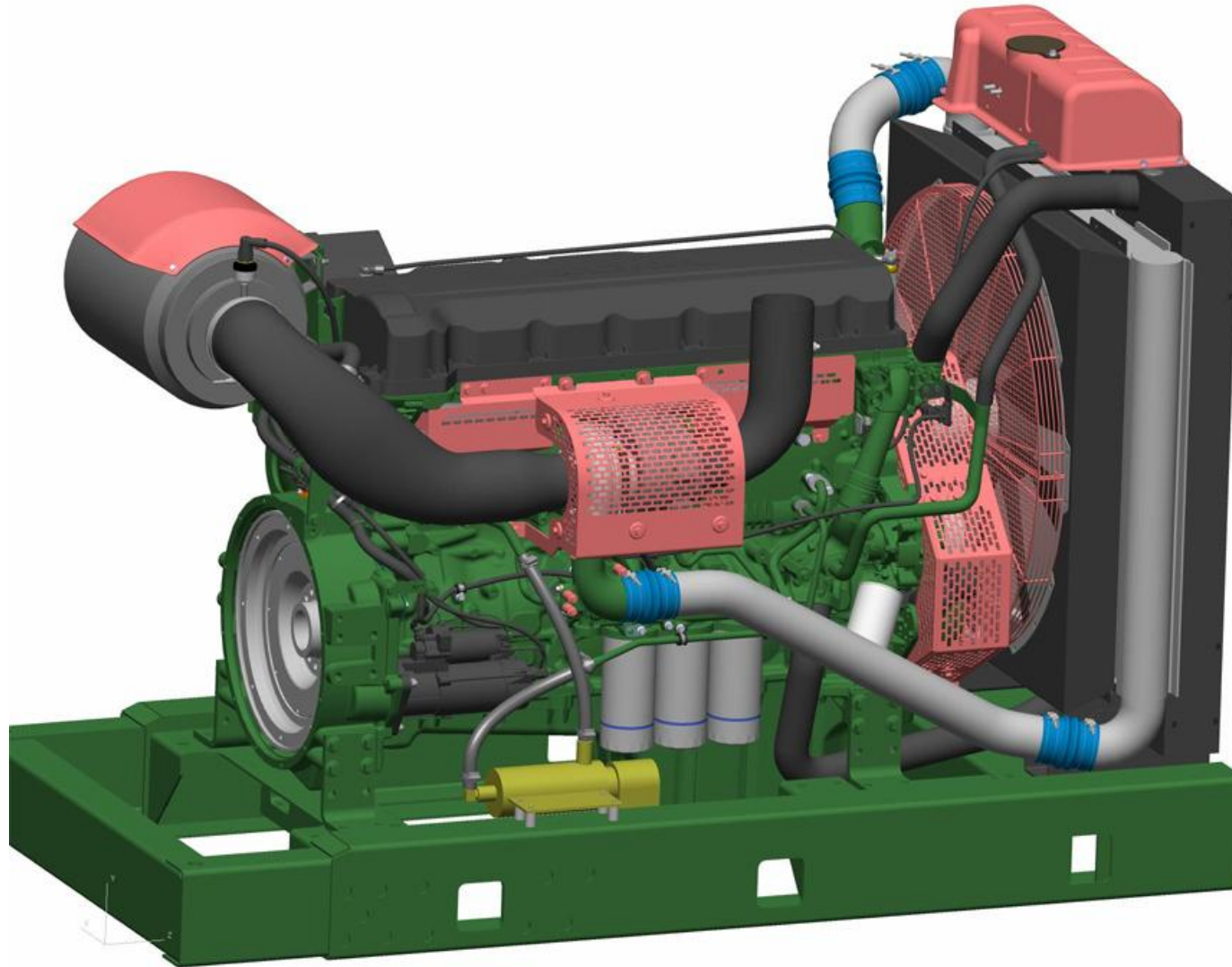

VP-SSK-1234-A-EN