



English

Deutsch

Español

Italiano

Français

Engine D16C

Technical data TAD1641VE

Engine designation:

Performance.....420 kW  
Torque (1200 r/min).....2731 Nm  
Rated speed.....2600 rpm

Number of cylinders.....6  
Number of valves.....24  
Displacement, total.....16,12 l  
Bore.....144 mm  
Stroke.....165 mm  
Compression ratio.....17,5 : 1

Dry weight, engine only....1440 kg  
Dry weight, power pack....1840 kg



red  
has  
s.  
ind  
is in  
  
osite  
k  
  
ed

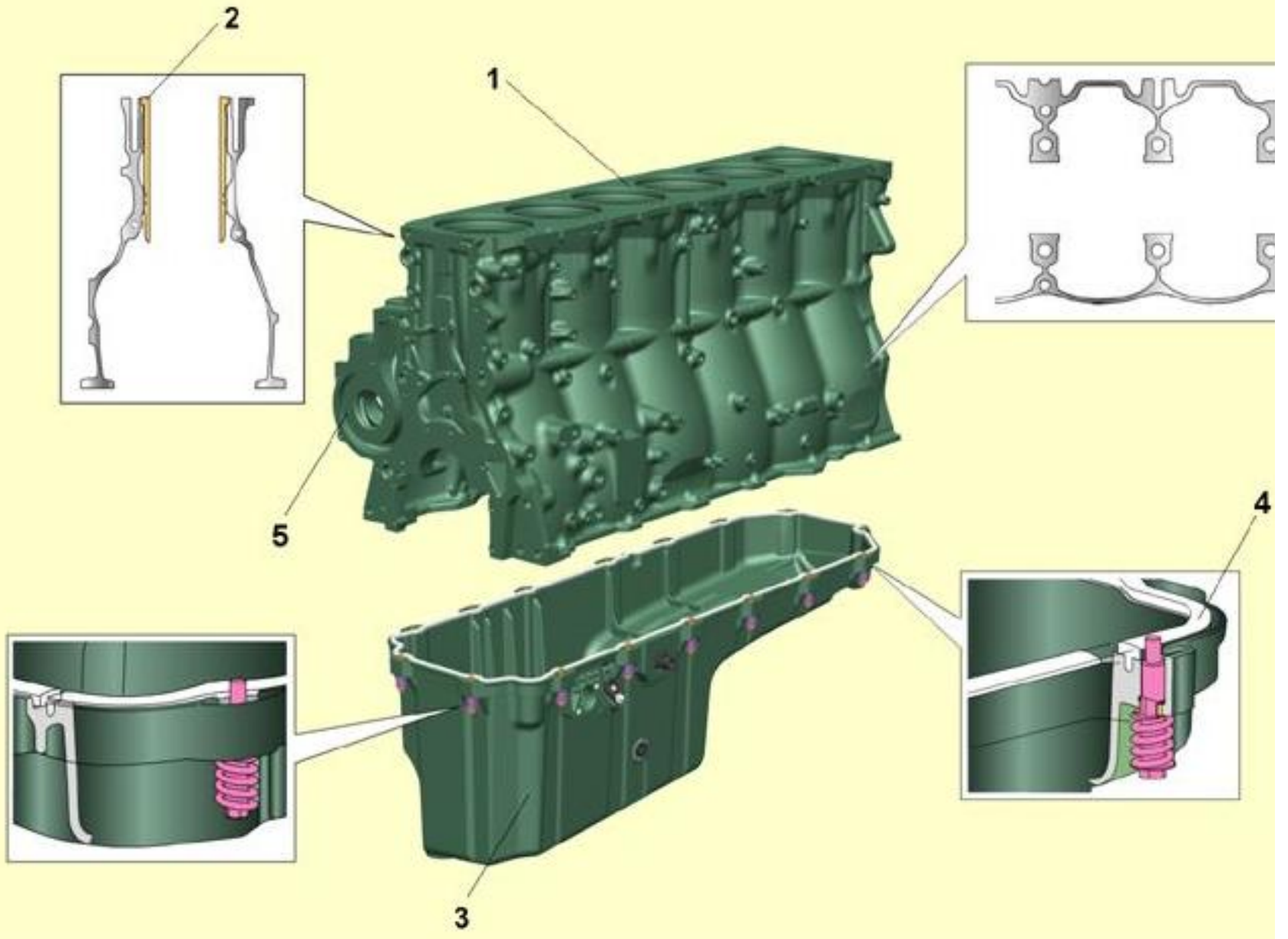

Menu

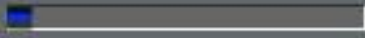

VOLVO PE

nd  
the  
r  
e  
ce  
a

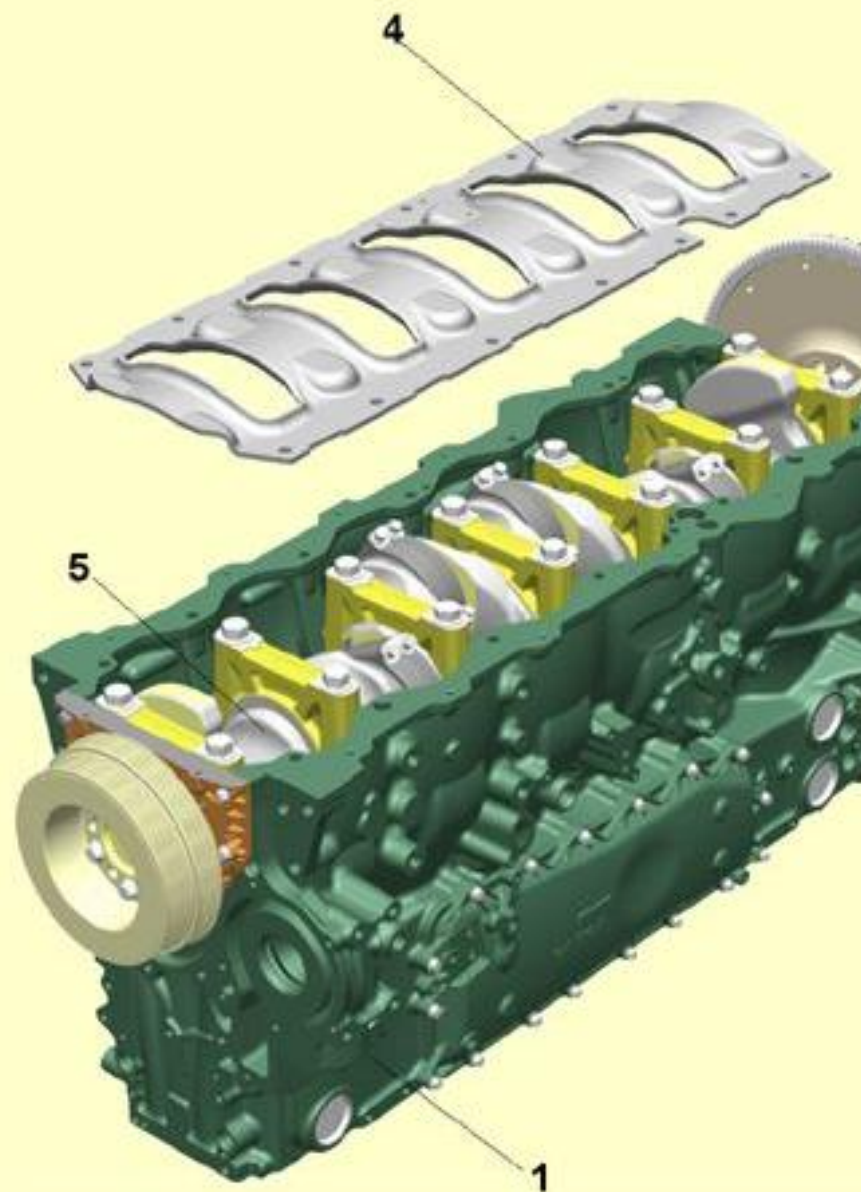
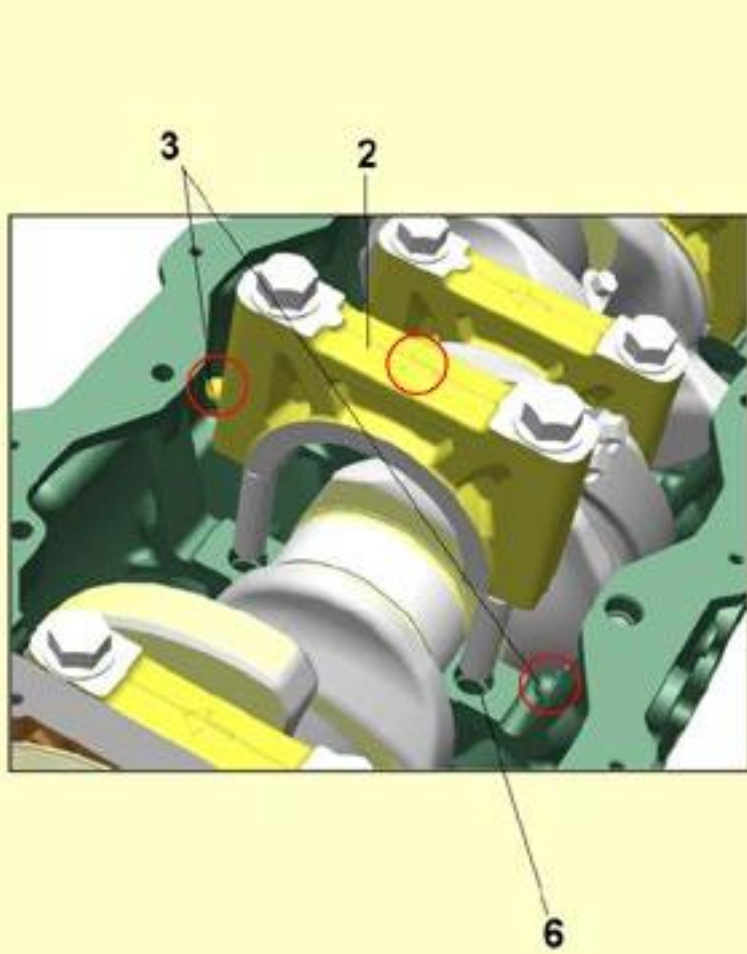

Menu

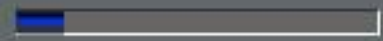

VOLVO P

## Cylinder liner and sealing joints

1. Cylinder liner
2. Sealing ring
3. EPDM sealing ring
4. O-ring
5. Cylinder head gasket
6. Coolant
7. Rubber seals
8. Convex embossing

The cylinder head gasket is one-piece solid steel for the whole engine. The gasket has vulcanized rubber seals for the oil and coolant passages. The gasket also has a number of pressed bosses that are used to protect the rubber seals in the cylinderhead gasket during assembly.

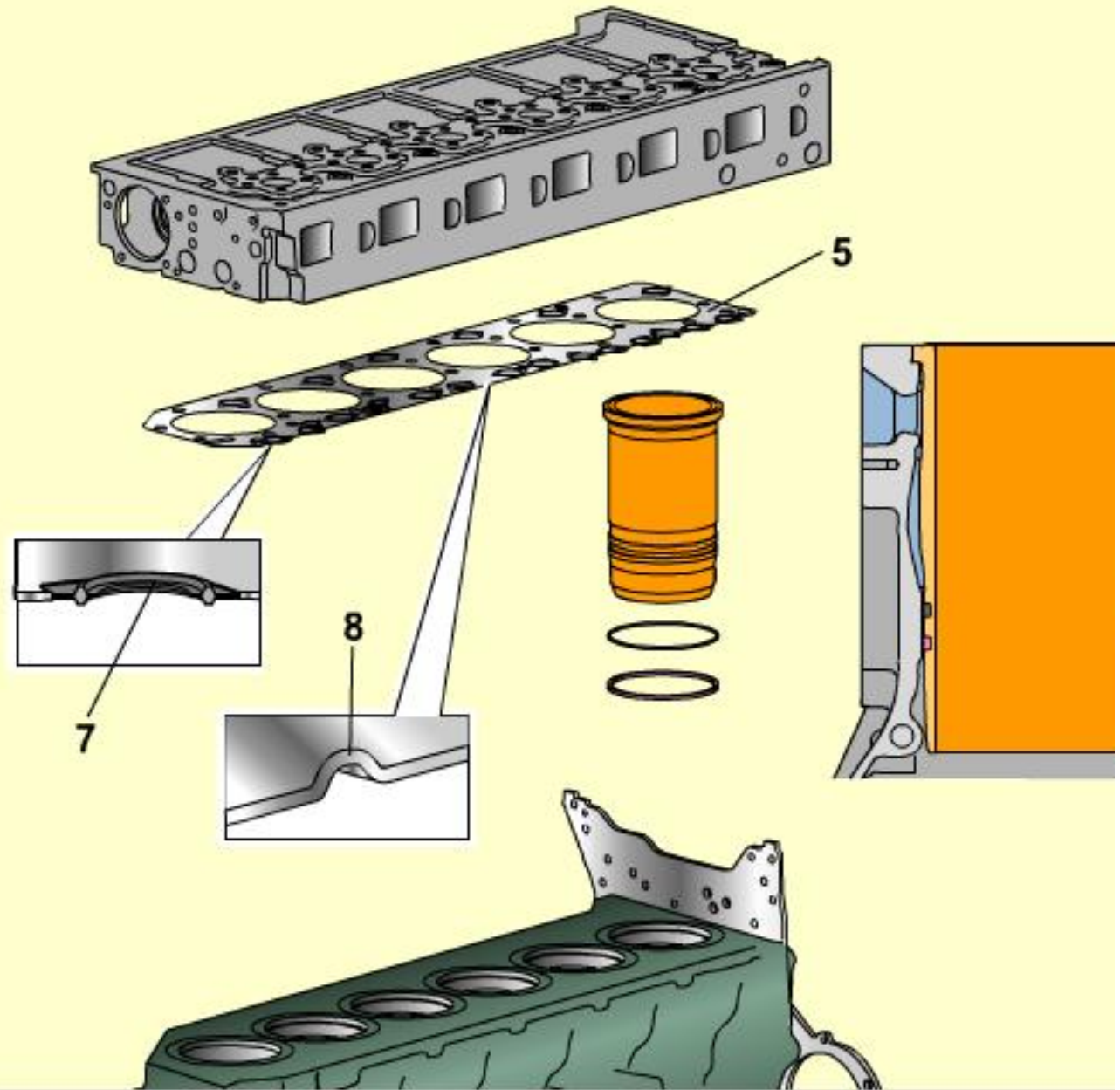

## Pistons and connecting rods

1. Cavity
2. Nozzle
3. Oil groove
4. Compression ring
5. Compression ring
6. Oil scraper ring
7. Connecting rod
8. Bearing race
9. Cap

The pistons are made of aluminum with cavity cooling using oil. Oil is sprayed up into a vertical passage in the piston via a nozzle in the cylinder block. The oil continues up to the circular passage in the piston crown.

The gudgeon pin bush is lubricated from oil grooves in the bushes.

The piston has three piston rings, two compression rings and one oil scraper ring.

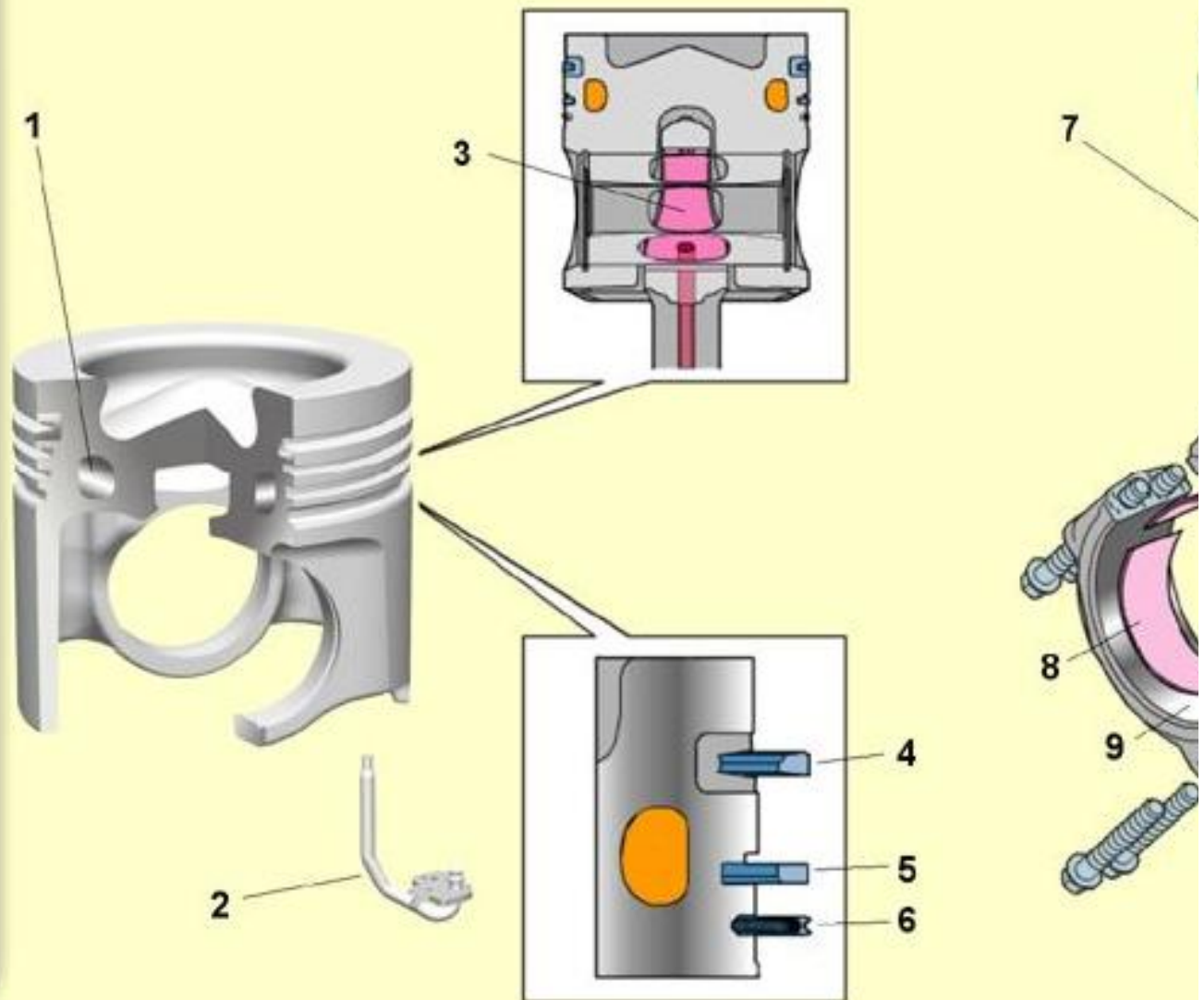

## Crank shaft

1. Crankshaft
2. Main bearing
3. Bearing cup
4. Axial bearing
5. Crankshaf gear
6. Hub
7. Oscilation damper
8. Steel ring
9. Fly wheel

The crankshaft is drop forged in one piece of alloy steel. There are seven main bearings and they are all hardened. The middle main bearing (4) also houses the axial bearing.

On the front end of the crankshaft is a hub for attaching the hydraulic oscillation damper/belt pulley (7).

The crankshaft timing gear (5) is screwed onto the rear end hub and

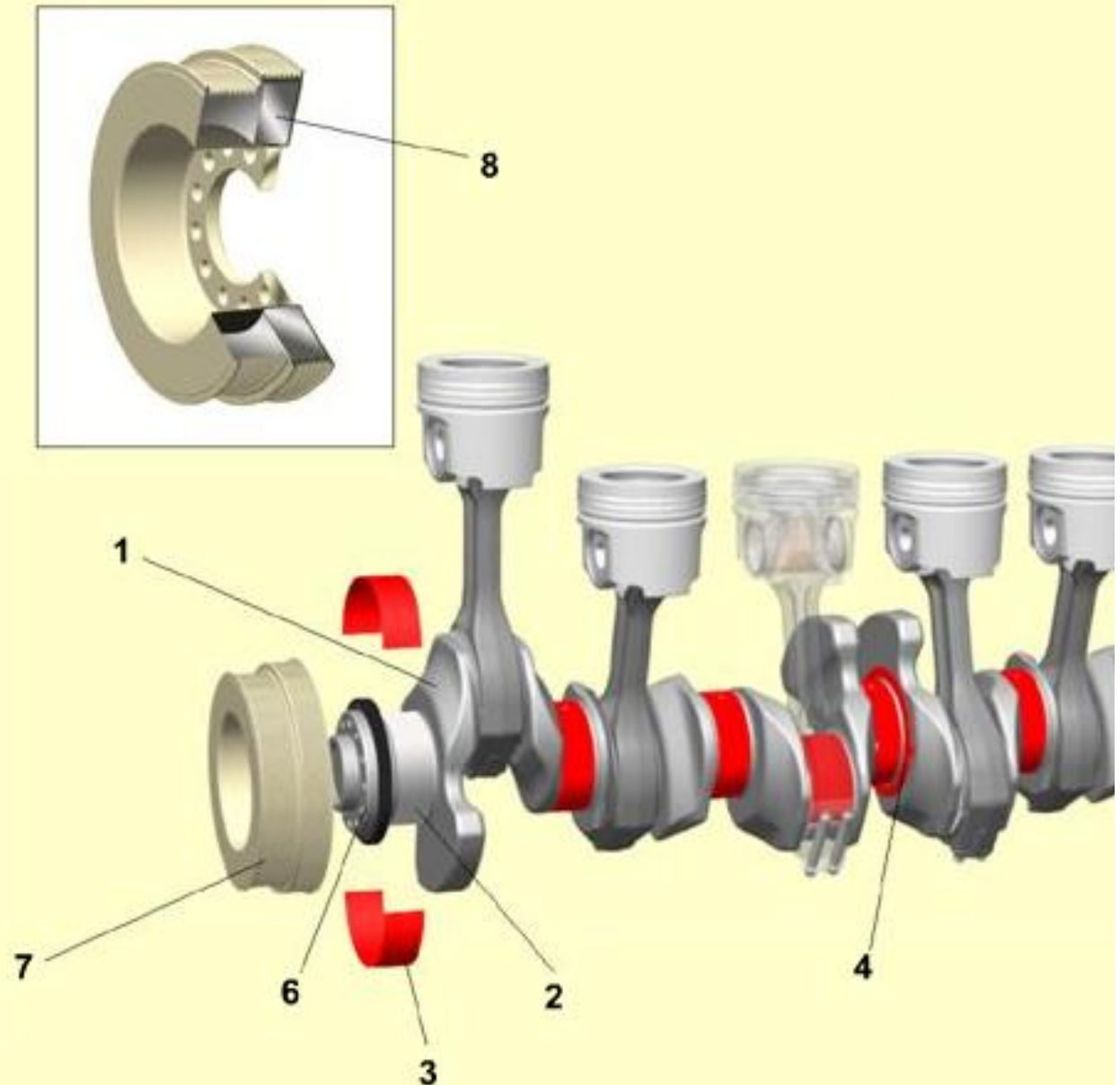

Manufactured in alloy. The  
cylinder  
is a  
overhead  
aft is  
aring  
bearing in  
ng.

ed centrally  
overhead  
art of the  
copper  
letely

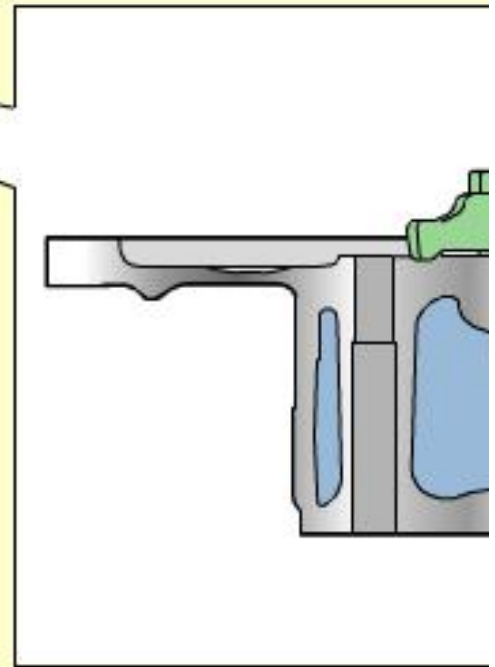
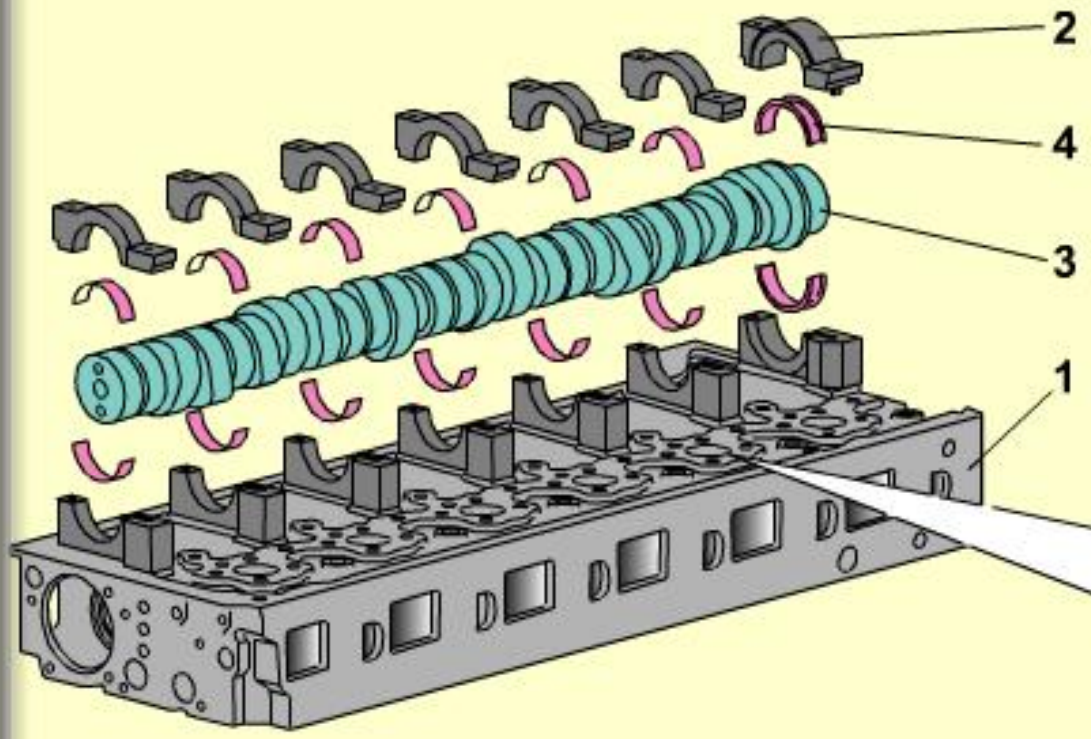



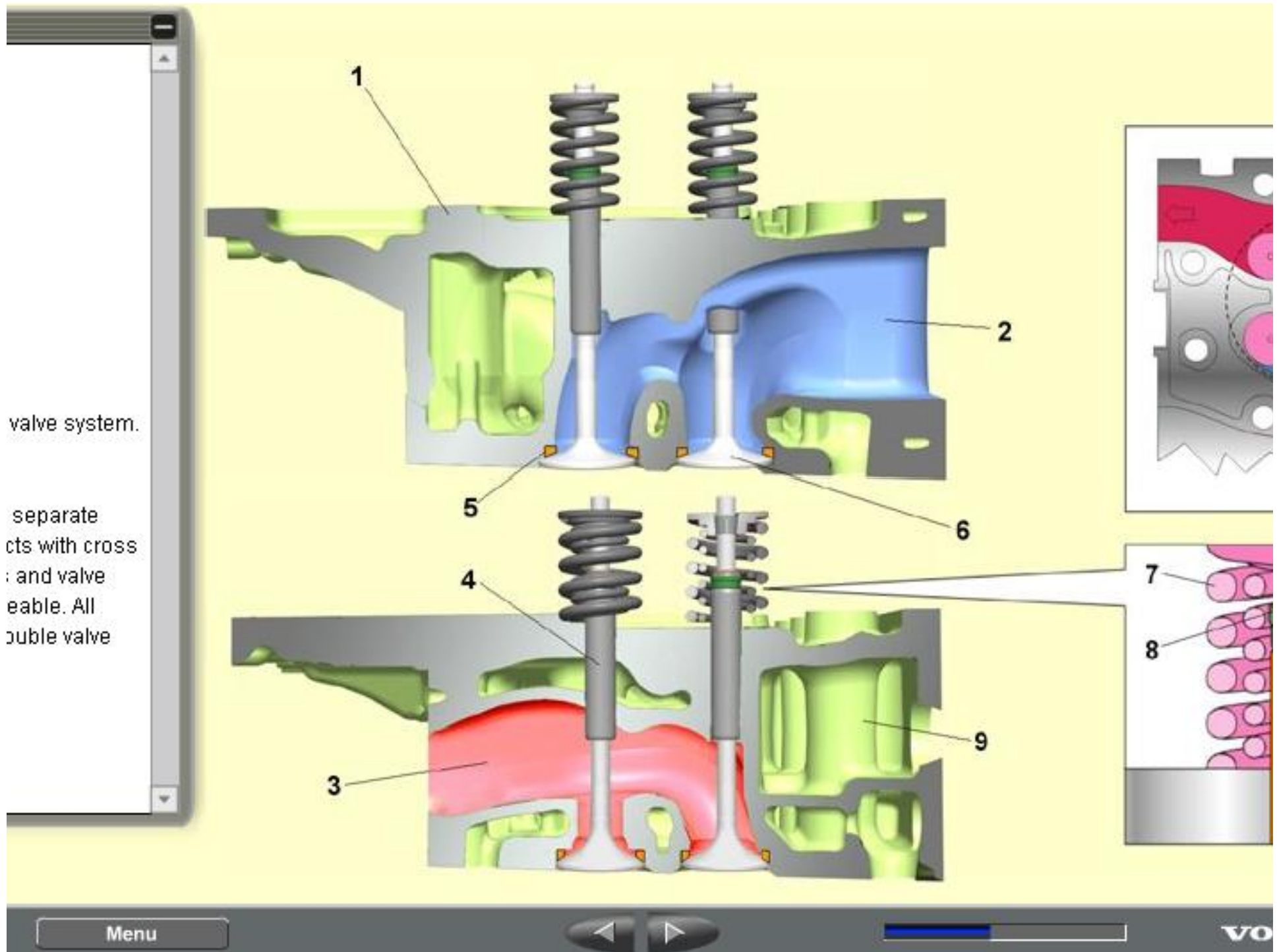

valve system.

separate  
cts with cross  
: and valve  
eable. All  
ouble valve

Menu

vo

er  
g  
sensor

is three cams  
ake cam, one  
cam between  
ctor. The  
7) has teeth (9)  
the camshaft

gs on the  
o adjust valves

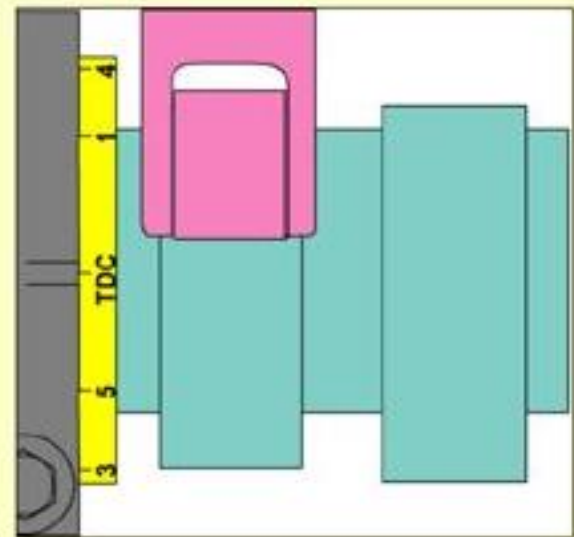
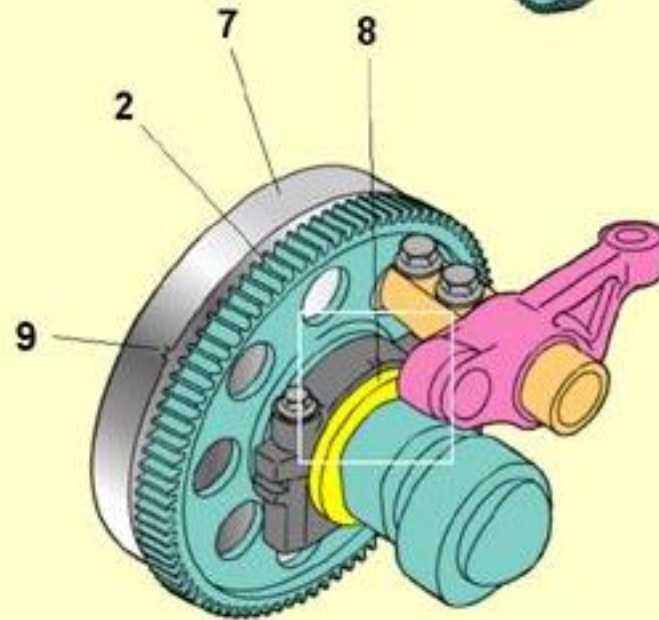
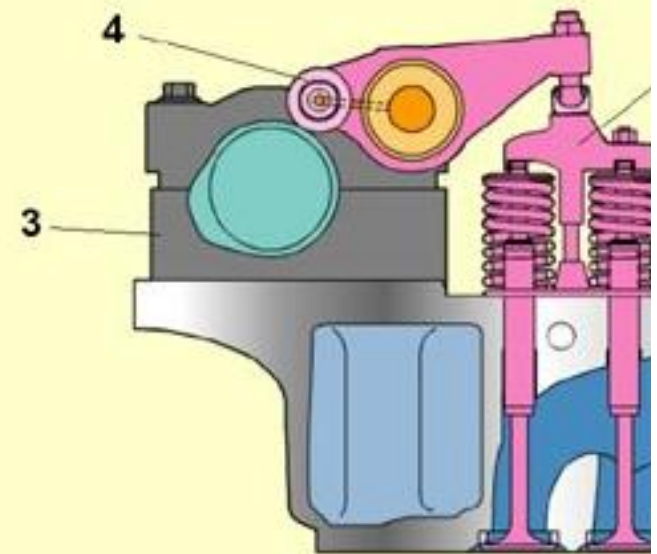
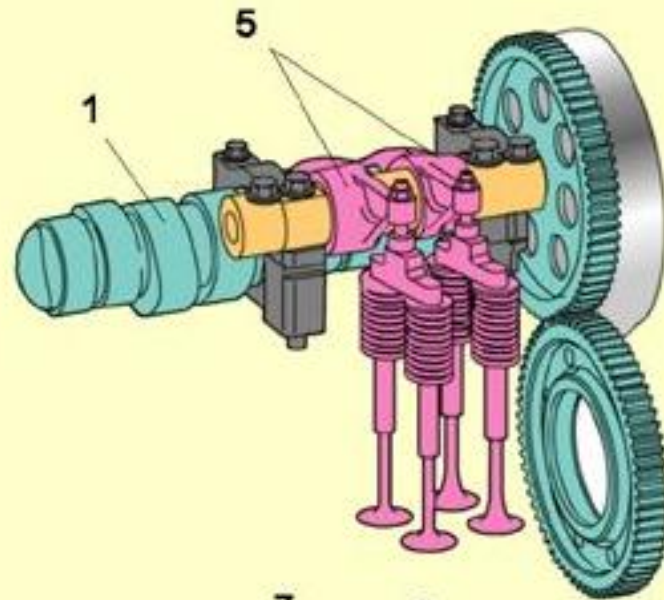

ar  
e  
r  
e gear  
gear  
r is located  
ne.  
helical.

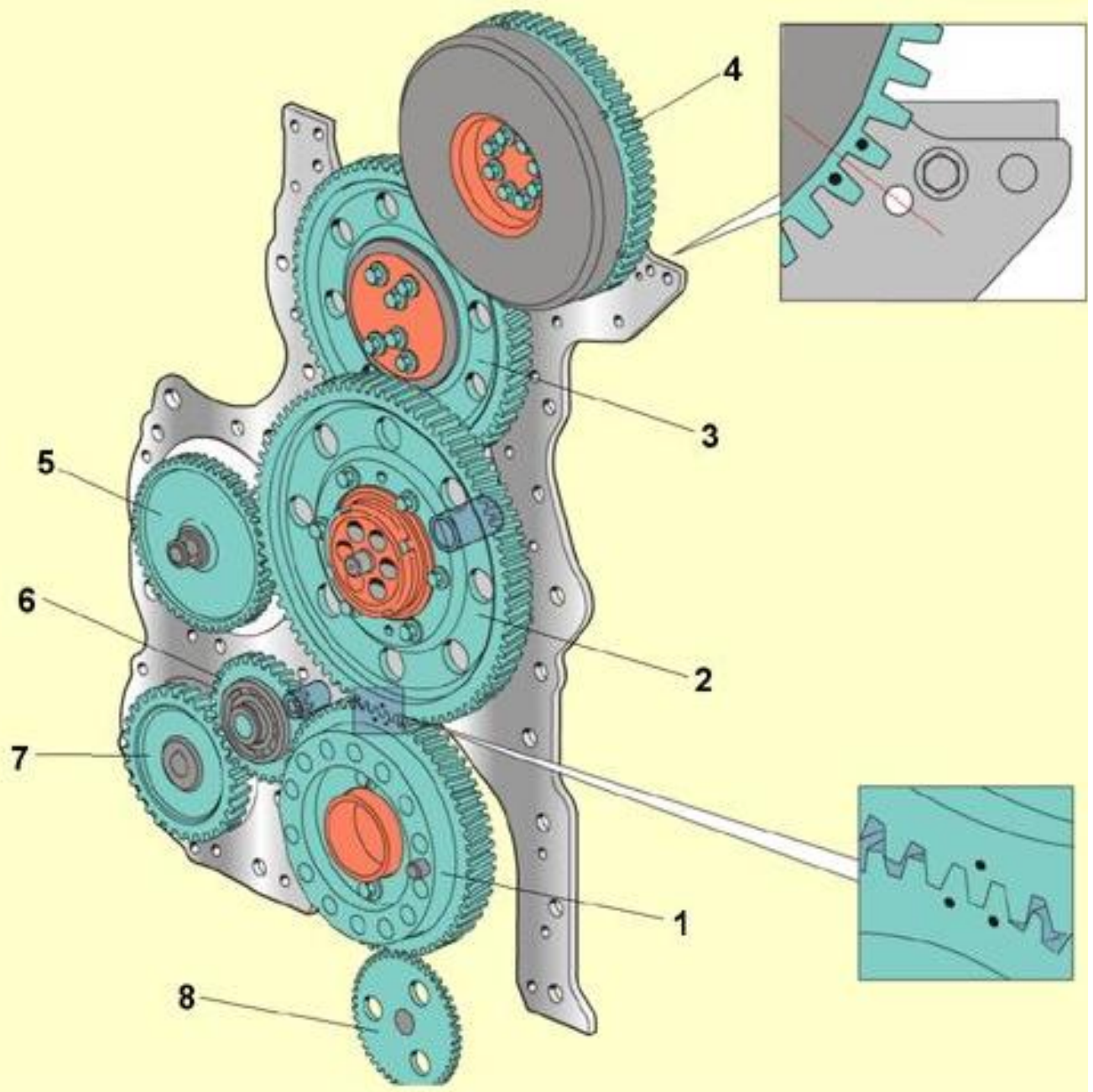

ssage  
age

lubricated with  
ated in the  
end of the  
the service-  
it has a remote  
ed at the rear

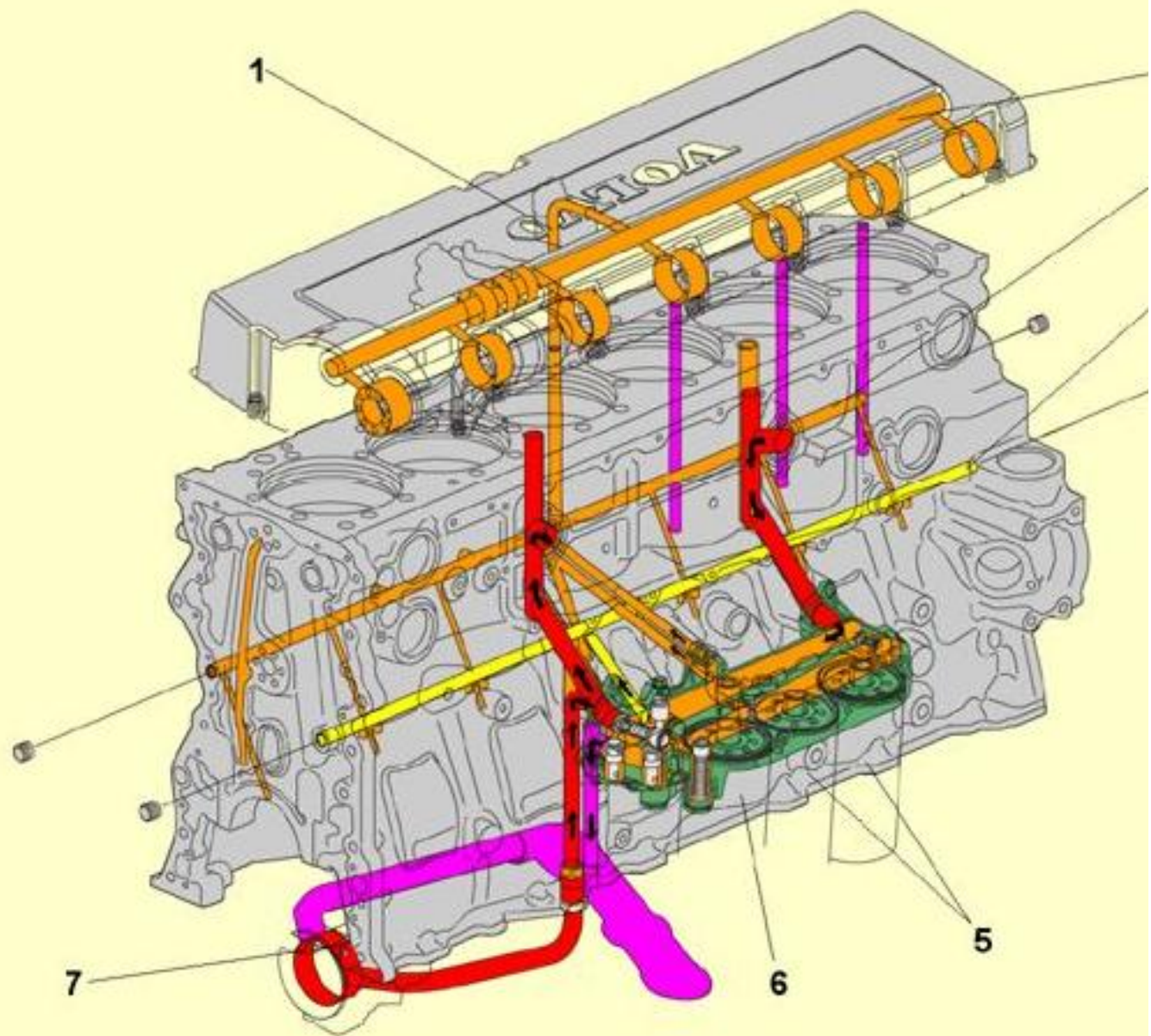

Menu



electronic unit  
h cylinder,  
high  
ressure is  
ns from one of  
afts and the  
t controls the

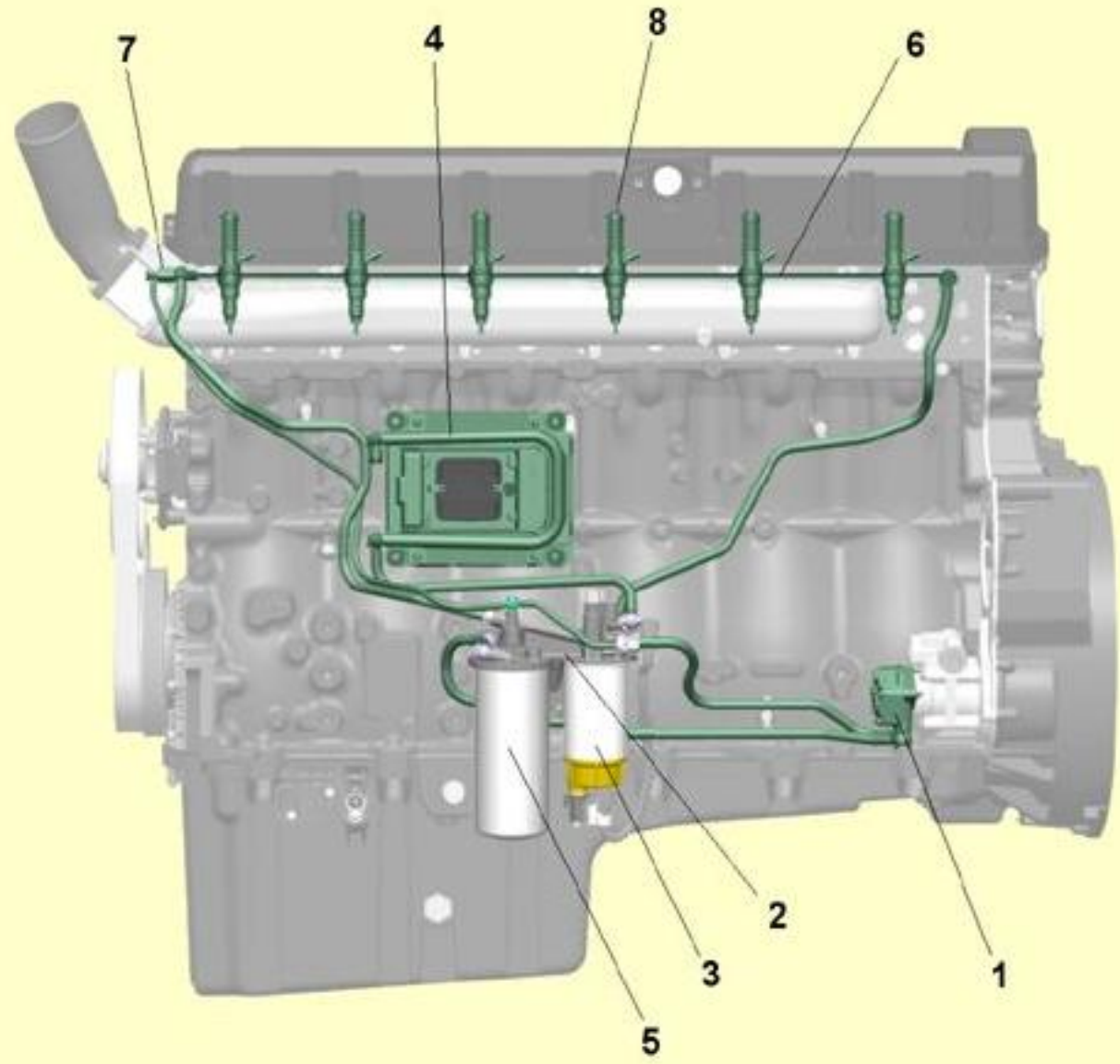

Menu



VOLVO

system

mid positioned  
ing and it  
arging.

lubricated and  
e oil and the  
rative to the  
compressor.  
mely essential  
cating system  
lly.

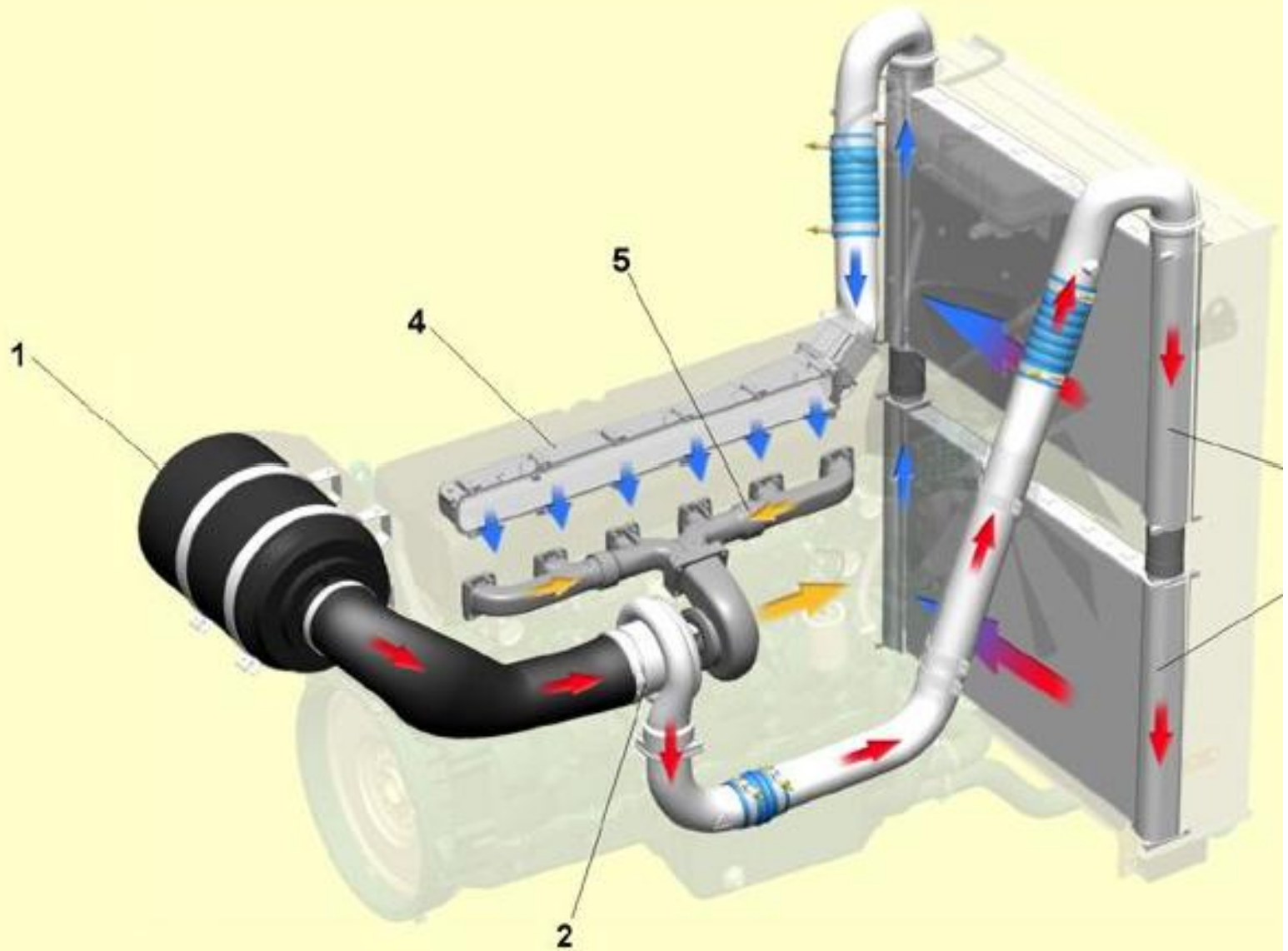

Menu

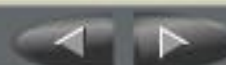

VOI

ed by the coolant  
ough the engine  
and passes the  
the temperature  
main thermostat  
rns the engine  
e.

stat  
at

nt pump  
ant in the cooling  
ngine is running.  
n has a coolant  
nt of coolant is  
ere an anti-  
added to the  
orrosion agent  
changing

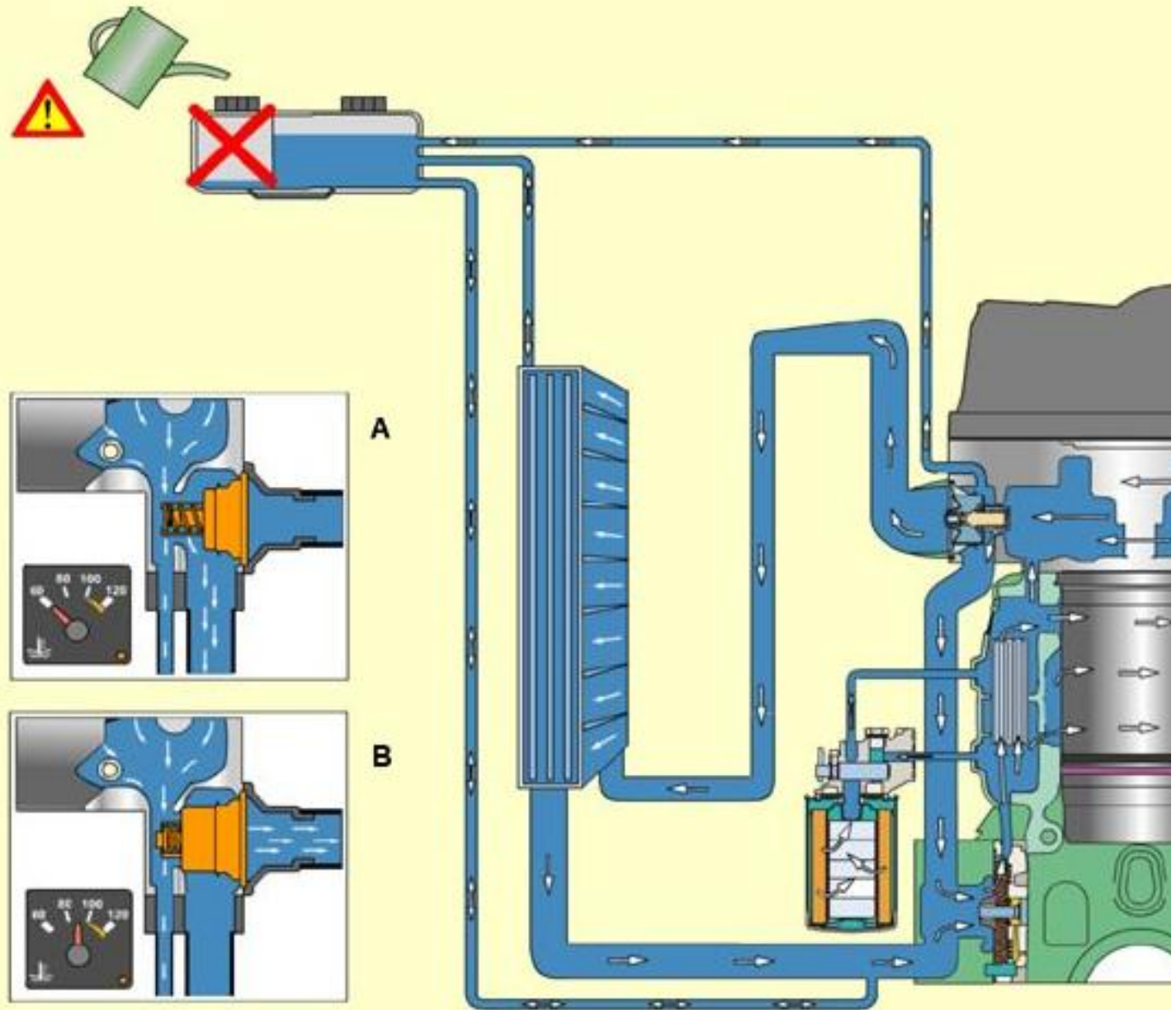

V

istic)  
JS

4 volt, 2-pole



2



5

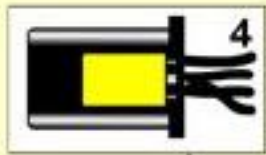

4

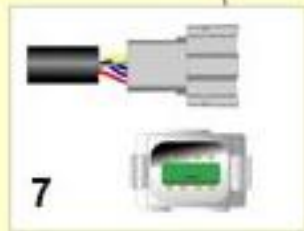

7

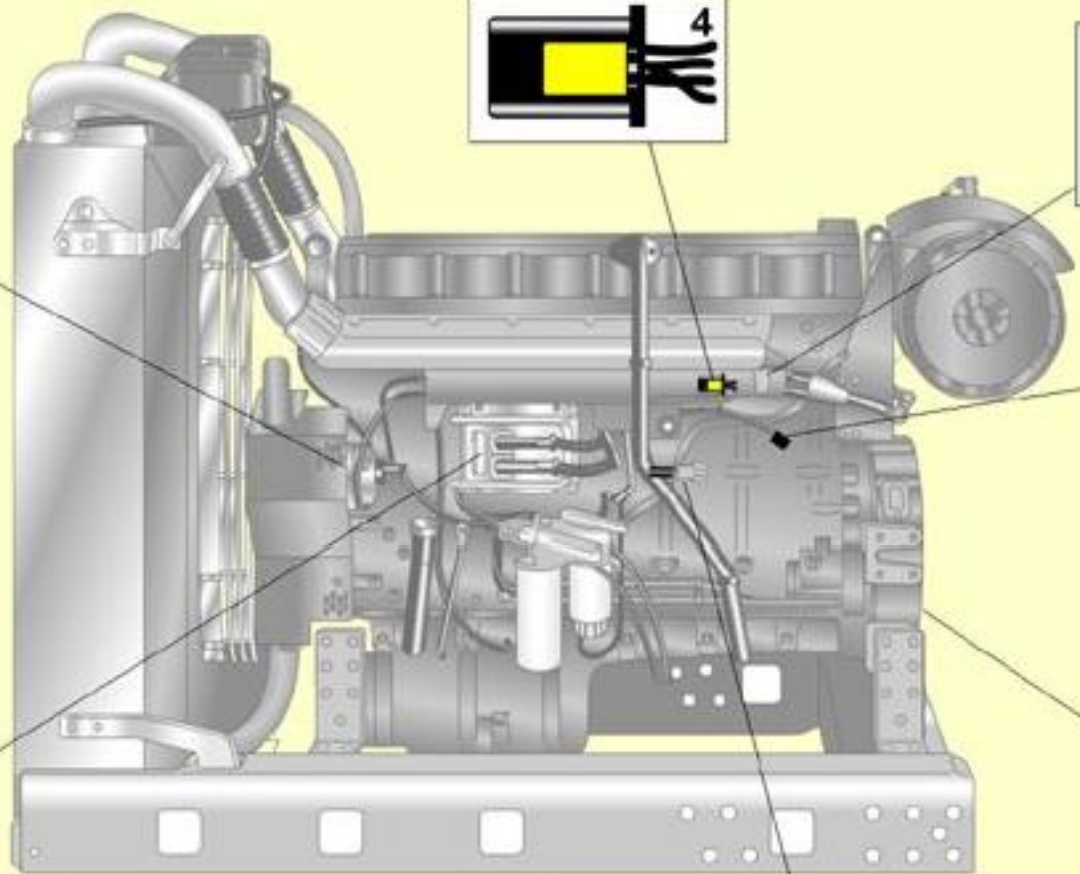

Menu



VO



fully  
lled engine. It  
lled EMS 2 and  
s.

ne  
n", and is an  
ith CAN  
diesel engines.  
s fuel control  
ion.

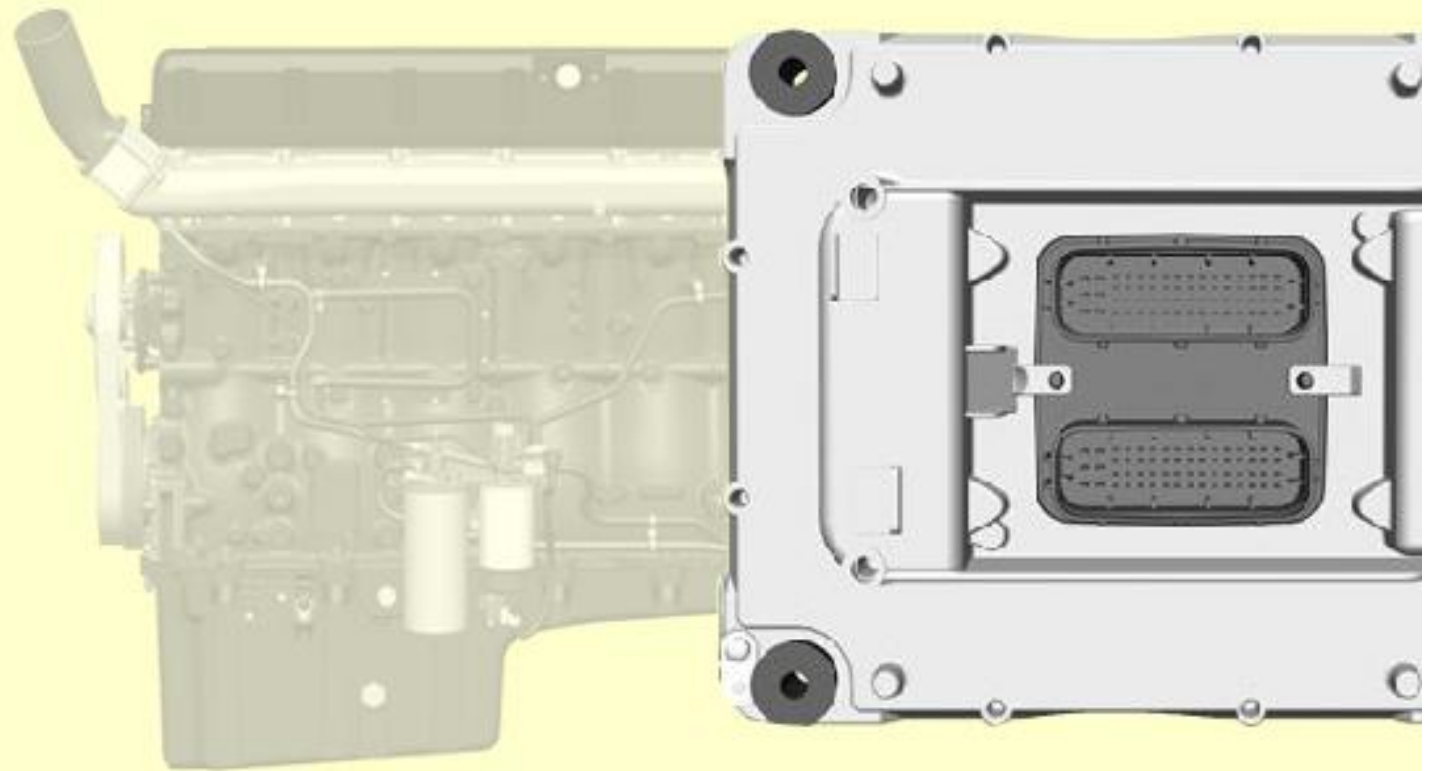

Menu



VOI

's can be found

ise pressure.

ature and  
sensor.  
n and engine

perature

sor.  
ng presence of

sor  
or.  
isor.  
sensor  
nsor

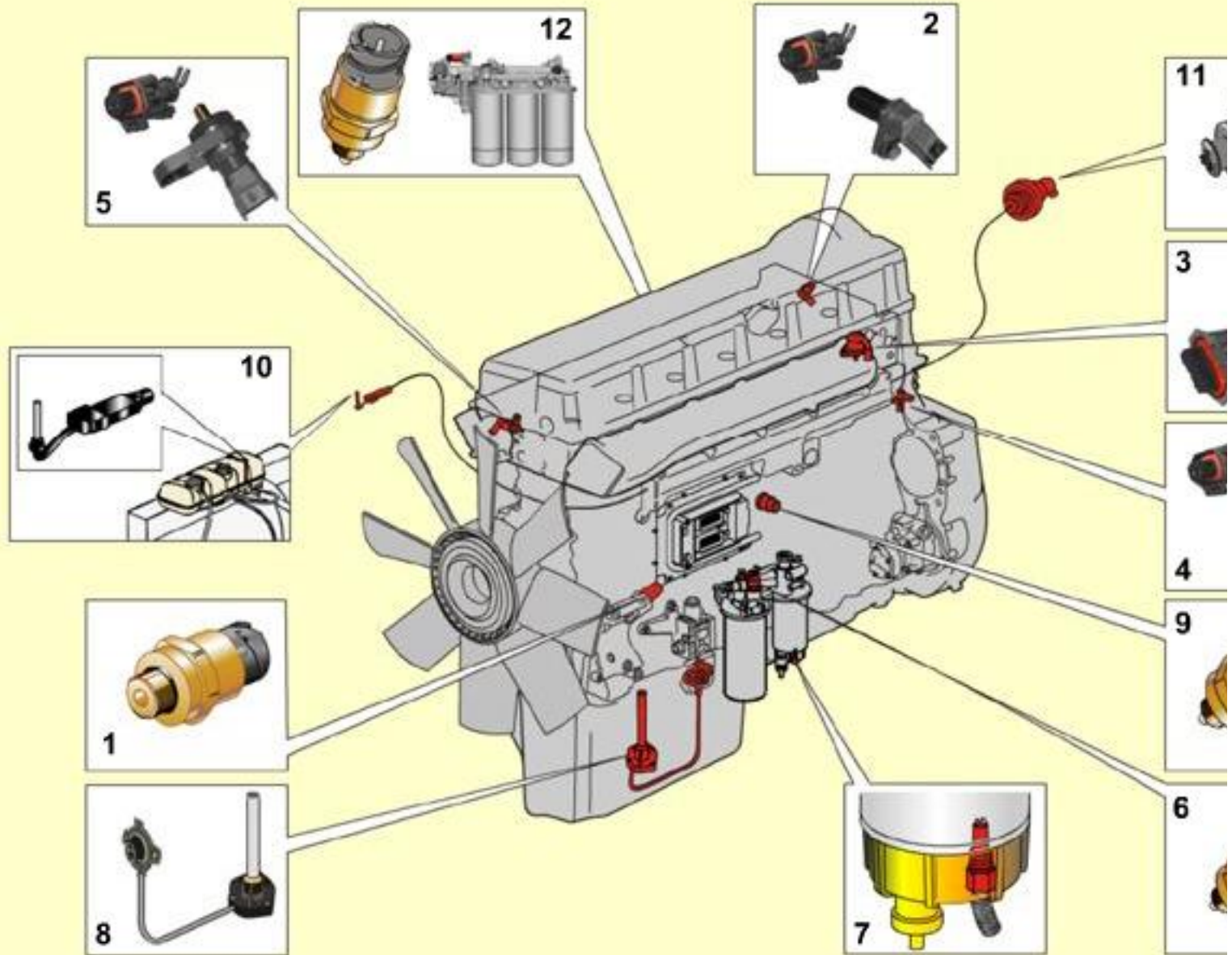

Menu



vo